



RANSOMES[®]

Parts Manual

AR 250

Series: VN - Engine type: Kubota V1505

Product code: LHAF001



WARNING: If incorrectly used this machine can cause severe injury. Those who use and maintain this machine should be trained in its proper use, warned of its dangers and should read the entire manual before attempting to set up, operate, adjust or service the machine.



INTRODUCTION

ITEM NUMBER

Each part which is identified in the illustrations has an item number. Parts which do not have an item number may not be readily identified in the illustration but are usually closely associated with the immediately adjacent part.

ASSEMBLIES

A complete assembly, e.g. a wheel motor or hydraulic motor or roll assembly, is listed as a complete item with subsequent individual components listed separately.

The assembly is listed under its part number with component parts being listed offset to the right, e.g.:-

ITEM	RANSOMES PART NO.	DESCRIPTION	QTY
1	LMSD798	Roll Assy.	1
2	MBB4490	• Tube	1
3	LMSD926	• End Cap Assy.	2
4	MBB6851	•• End Cap	1
5	H009116	•• Bearing	1
6	MBB2356	•• Seal Housing	1
7	A224016	• Seal	2
*	A122192	Screw	2

It may not be possible to illustrate every item. With certain items purchased from outside suppliers some component parts may not be available from Ransomes and may need to be specially ordered from the supplier e.g. Volvo hydraulic motor components.

QUANTITIES

Quantities shown are for one assembly or sub-assembly.

USING THE PARTS LIST

Determine the function and application of the part required. Turn to the main index page and select the appropriate section. Locate the part on the illustration and parts list and read off the quantity from the appropriate MODEL column.

NUMERICAL INDEX

This is a summary of all part numbers used in the manual arranged in numerical sequence and showing the page and item number under which the parts appear.

ORDERING OF SPARE PARTS

When ordering replacement parts, it is most important to quote the SERIAL NUMBER of the machine, PART NUMBER, DESCRIPTION and QUANTITY required.

AR 250	VN000301
2000	
KG 1270	KW 28
CE	RANSOMES JACOBSEN LTD. IPSWICH ENGLAND

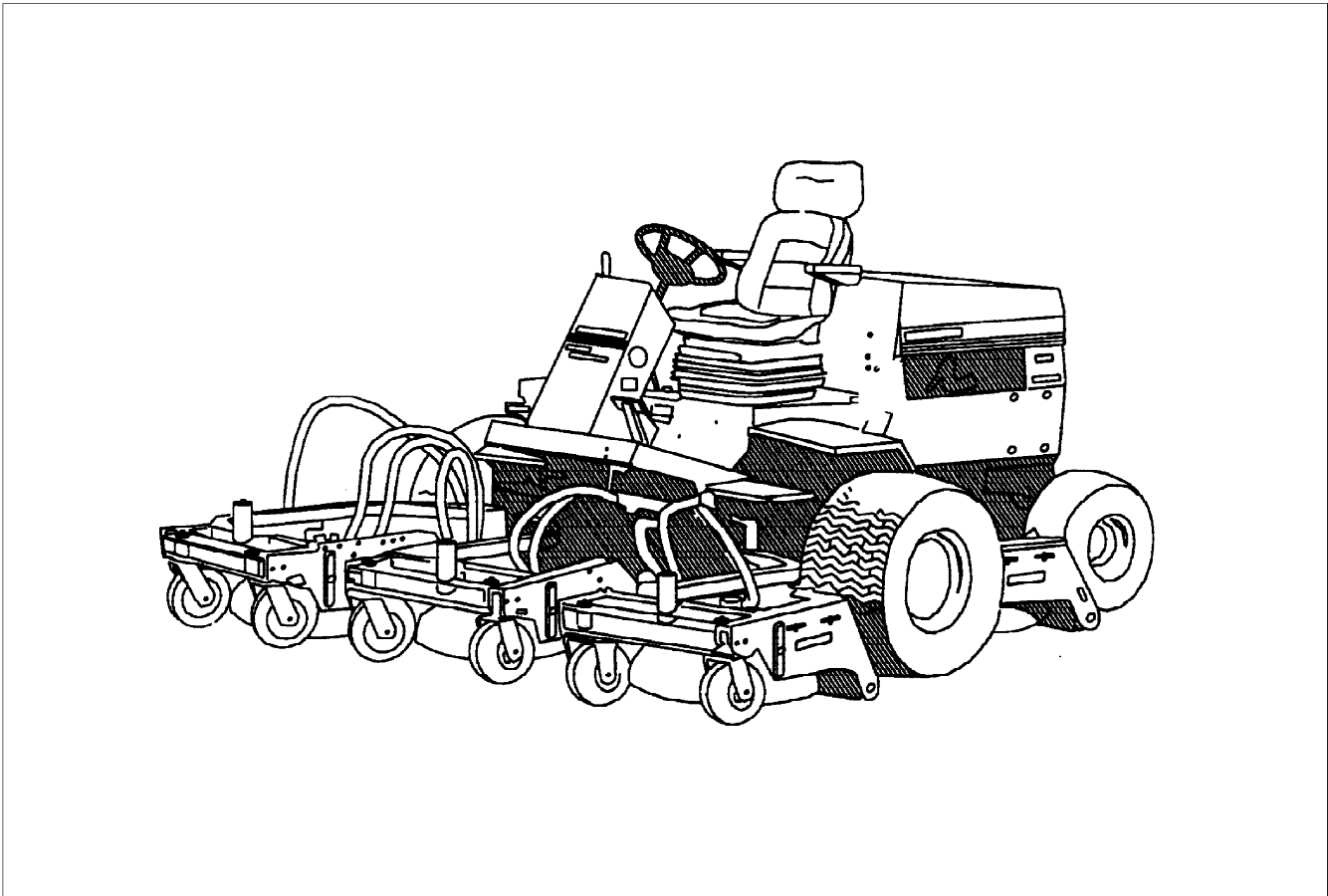

SPECIFICATIONS

ENGINE SPECIFICATION

TYPE: Kubota 28KW (38HP) @ 3000 RPM, 4 cylinder (in line) vertical Diesel engine, 4 stroke, water cooled, 1498cc cu.in) with 12V electric start.

(91.44 electric start.

Model: V1505-BBS-EC-1

Maximum Speed: 3000 \pm 50 RPM (No load)

Idle Speed: 1500 RPM

Oil Sump Capacity: 6 litres (10.56 Imp.pints) (12.68 US pints)

Firing Order: 1, 3, 4, 2.

Fuel: No. 2-D Diesel fuel (ASTM D975)

MACHINE SPECIFICATION

Speeds:

Cutting: 0 - 12km/h (0 - 7.5 mph) FORWARD
0 - 6.4km/h (0 -4 mph) REVERSE

Transport: 0 - 16km/h (0 - 8.5mph) FORWARD

Tyres:

Front - 26.5 x 14.00 - 12 4 ply rating turf tread

Rear - 20 x 10.00 - 8 4 ply rating turf tread

Pressures: All tyres 1 kg/cm² (14p.s.i.)

Construction: Heavy duty formed steel chassis with box section frame rails.

Transmission: Full time 4-wheel drive. Direct coupled variable displacement pump to direct coupled 29 cu in front, 21 cu in rear wheel motors.

Brakes: Hydrostatic braking with mechanical type band parking brakes, 260mm x 45mm (10.25in x 1.75in) on front wheels.

Steering: Hydrostatic power steering, with adjustable tilt steering wheel.

Cooling System

Capacity: 4litres (7 Imp. pints) (1.06 US gals)

Fuel Tank

Capacity: 45.4 litres (10 Imp. galls) 12 US galls

Hydraulic Tank

Capacity: 37.8 litres (8.3 Imp. galls) 10 US galls

DIMENSIONS

Width of cut: 2.5 metres (98in)

Overall width: (transport) 2.13 metres (84in)

Overallwidth: 2.6metrew (104in)

Overall height: 1.4 metres (56in)

Overall length: 3.1 metres (122in)

Overall weight of machine: 1270kg (2800lb)

NOISE EMISSION

Conforms to the specification of Directive EEC 79/113, 84/558, 87/252, 88/180, 88/181.

Sound Power Level: 104dB(A) LWA (By-stander)

Sound Pressure Level: 85.7dB(A) LpA (Operator Ear Level)

VIBRATION LEVEL

The machine was tested for whole body and hand/arm vibration levels. The operator was seated in the normal operating position with both hands on the steering mechanism. The engine was running and the cutting device was rotating with the machine stationary.

Hand / Arm acceleration level : 0.46 m/s²

Whole body acceleration level

X axis : 0.014 m/s²

Y axis : 0.027 m/s²

Z axis : 0.020 m/s²

RECOMMENDED LUBRICANTS

Engine oil: Should be to MIL-L-2104C or to A.P.I. Classification CE grades and as given in the table below:

Temperature	Oil Viscosity
ABOVE 25°C (77°F)	SAE 30
0°C to 25°C (32°F to 77°F)	SAE 20
BELOW 0°C (32°F)	SAE 10w

Hydraulic Oil: To A.P.I. Classification CE/SF grades SAE 10w-30

Grease: Shell Darina R2 or equivalent.

CUTTING UNIT SPECIFICATION

General: Five 559mm (22in) rotary mulching decks supported by equal ratio lift arms.

Drive: Fixed displacement hydraulic motors directly coupled to cutting unit.

Control: Cutting unit lift lever with automatic shutoff and safety interlock restart.

Construction: Heavy duty, welded pressed steel.

Suspension: Steerable floating head.

Cutting Blades: Patent pending twin blades. Lower blade 559mm (22in), upper blade 546mm (21.5in)

Height of cut: Adjustable in 6mm (0.25in) increments; no tool required.

Rear roller: 102mm (4in) diameter smooth roller.

Contents

FRAME AND REAR AXLE	5
ENGINE MOUNTING	9
HYDROSTAT / THROTTLE CONTROL	11
FILTER MOUNTING	15
STEERING WHEEL AND PEDAL MOUNTING	17
FRONT LIFT ARM MOUNTING	21
REAR LIFT ARM MOUNTING	25
DRIVE WHEELS AND BRAKES	29
HYDRAULIC RESERVOIR AND FUEL TANK	31
HOOD AND RADIATOR	33
SEAT MOUNTING	35
SEAT BREAKDOWN GRAMMER (S 85 / 90R)	39
SEAT SUSPENSION BREAKDOWN GRAMMER DS85H	43
INSTRUMENT PANEL	45
HYDRAULIC VALVE MOUNTING	47
ENVIRODECK	49
SIDE DISCHARGE DECK	53
ELECTRICAL SYSTEM	57
HYDRAULIC SYSTEM	59
VALVE 4 WHEEL DRIVE	67
DECK VALVE	69
TRANSMISSION PUMP (SAUER SUNDSTRAND)	71
DECALS	73

RANSOMES
AR 250
SERIES: VN

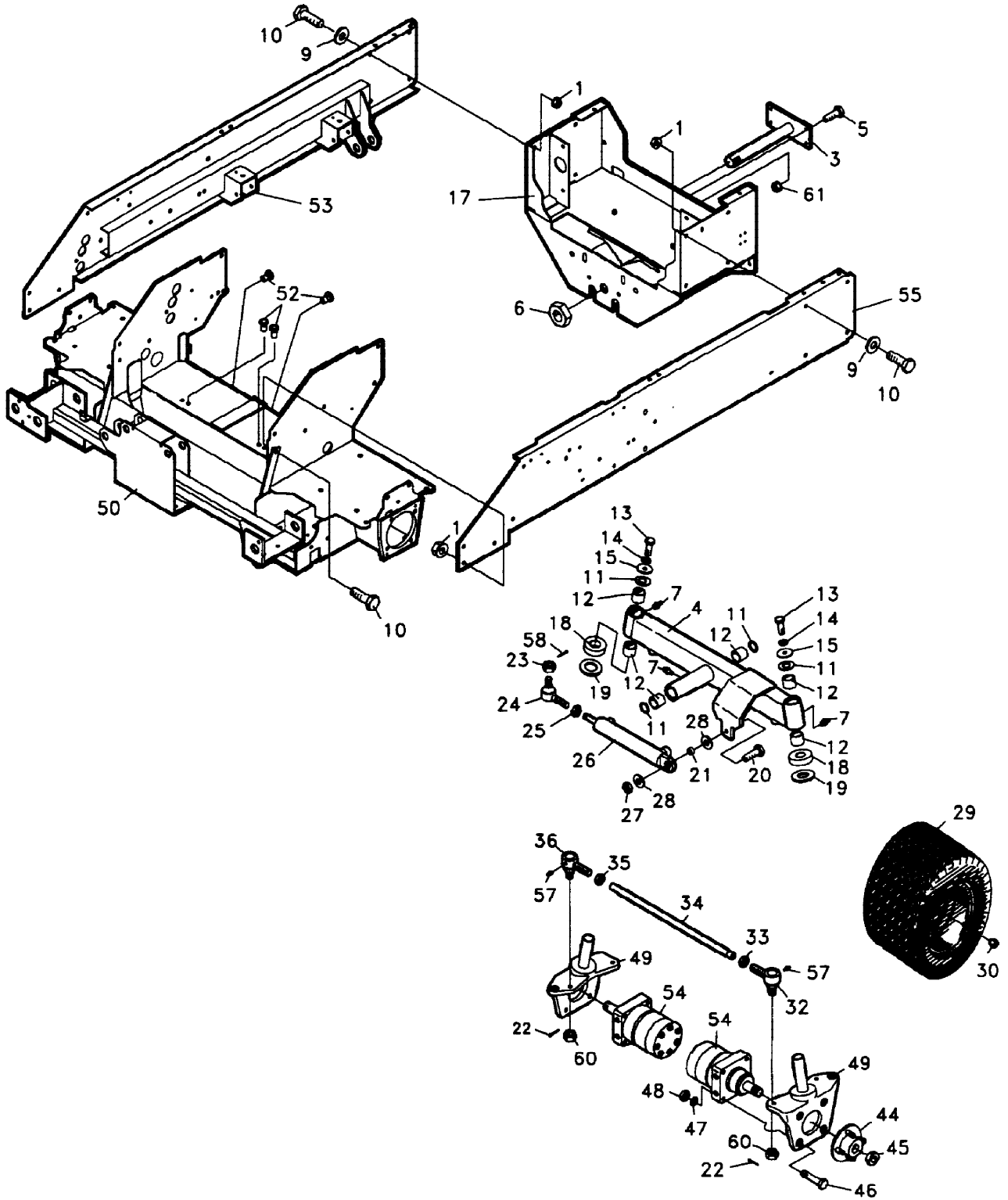

FRAME AND REAR AXLE

LIST OF PARTS

ITEM	RANSOMES PART NO	DESCRIPTION 	QTY	REMARKS
1-1	450380	LOCKNUT NYLON M12-1.75	14	
1-3	2206030	WLDMT REAR AXLE PIVOT	1	
1-4	2206101	S REAR AXLE ASSY (INCLUDES ITEMS 7 & 12)	1	
1-5	450191	BOLT M 8 - 1.25X20	4	
1-6	A139382	NUT HEX 1-1/4-12 NYLOCK	1	
1-7	GSF2540AC	ZERK	3	
1-9	450392	WASHER	12	
1-10	450241	BOLT M12-1.75X30	14	
1-11	62464-4A	WASHER, THRUST	4	
1-12	W108003	BUSHING	6	
1-13	450213	BOLT-M10-1.5X20	2	
1-14	450412	LOCKWASHER M10	2	
1-15	64163-17	WASHER	2	
1-17	2206142	WLDMT-REAR FRAME	1	
1-18	W178018	THRUST BEARING	2	
1-19	173042	SPACER-SPINDLE	2	
1-20	64123-24	BOLT HEX 1/2-13X2	1	
1-21	2203049	BUSHING-STEERING CYL	1	
1-22	64140-1	COTTER PIN 1 1/8 X 1	2	
1-23	306825	NUT, 7/16-20 CASTLE	1	
1-24	A814549	TRACK ROD END	1	
1-25	800490	NUT M14 - 1.5	1	
1-26	198040	CYLINDER, STEERING	1	(USE 198040-01 SEAL KIT)
1-27	W64151-7	1/2-13 HEX LOCKNUT	1	
1-28	A159408	WASHER	2	
1-29	178032	ASSY - WHEEL 20X 10X8	2	
	178032-01	• S - TIRE 20X10X8	AR	
	118082	• S - RIM 8" 4 BOLT	AR	
1-30	A134111	WHEEL NUT 1/2 - 20	8	
1-32	128079	ROD END	1	(INCLUDES ITEM 60)
1-33	450334	NUT M16 THIN	1	
1-34	MBG2163	TIE ROD	1	
1-35	64025-16	NUT 5/8 - 18 RH	1	
1-36	128079	ROD END	1	(INCLUDES ITEM 60)
1-44	BAM6152A	WLDMT-WHEEL HUB	2	
1-45	MBF1355	NUT 1-20 UNSLOTTED TRW	2	
1-46	450056	BOLT-M12-1.75X80	8	
1-47	GSF2163L	LOCKWASHER 1/2	8	
1-48	450326	NUT-HEX M12-1.75	8	
1-49	MBG2292	PLATE MOTOR	2	
1-50	2206076	S FRAME FRONT W/LABS	1	
1-52	450372	INSERT-GRIP MI 0-1 .5X21 .20	4	
1-53	MBF0644E	WLDMNT-FRAME RAIL RH	1	
1-54	148141-07	WHEEL MTR ME21 0208MBT	2	

* Not Illustrated

RANSOMES
AR 250
SERIES: VN

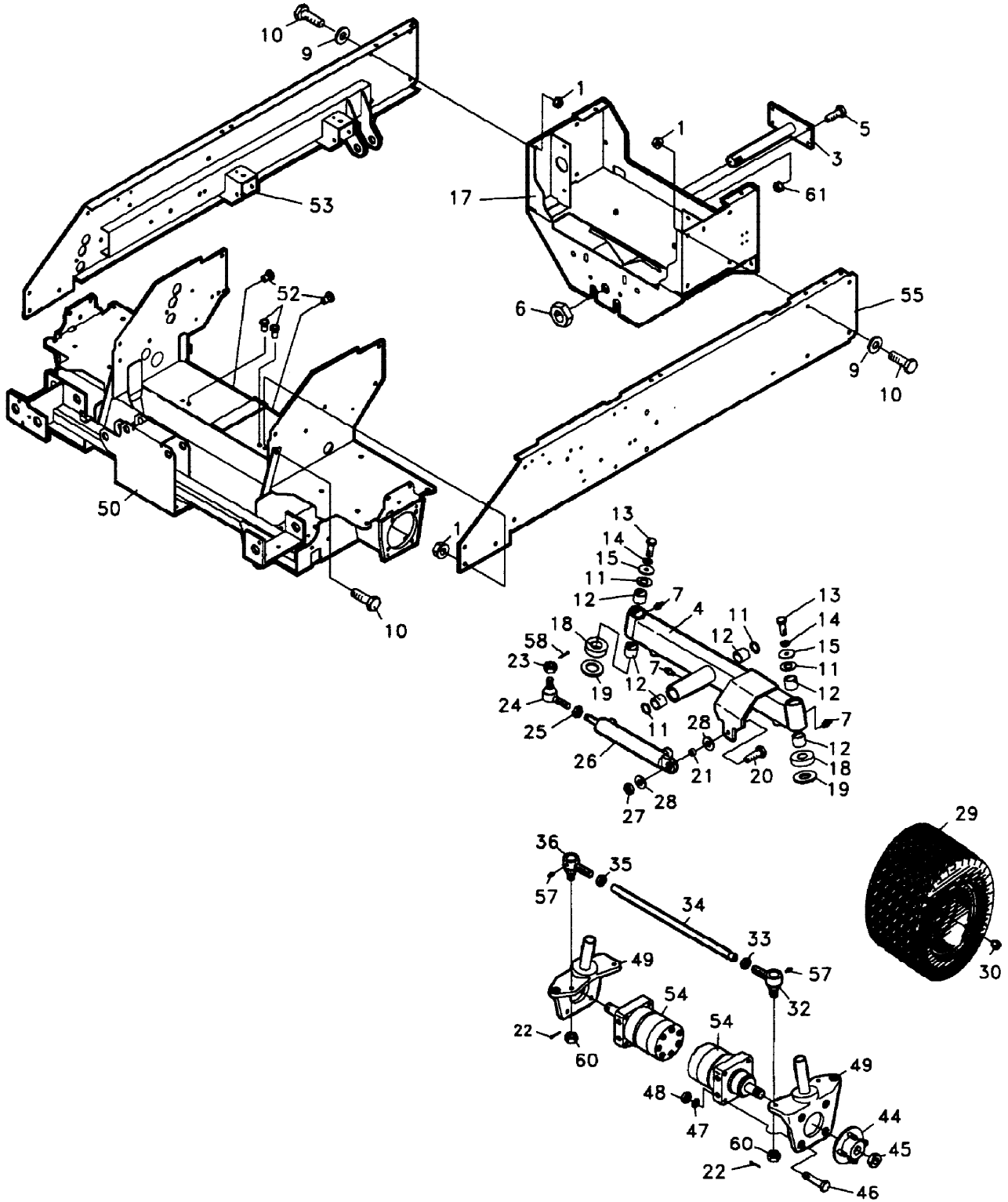

ITEM	RANSOMES PART NO	DESCRIPTION 	QTY	REMARKS
1-55 1-57 1-58 1-60 1-61	2206024F 35027N 64140-3 64025-30 450378	(USE SEAL KIT 148138) (USE KEY 64164-08) WLDMNT-FRAME RAIL LH GREASE ZERK COTTER PIN 3/32 X 3/4 NUT-HEX 1/2-20 SLOT NUT-M8	1 2 1 2 4	

* Not Illustrated

RANSOMES
AR 250
SERIES: VN

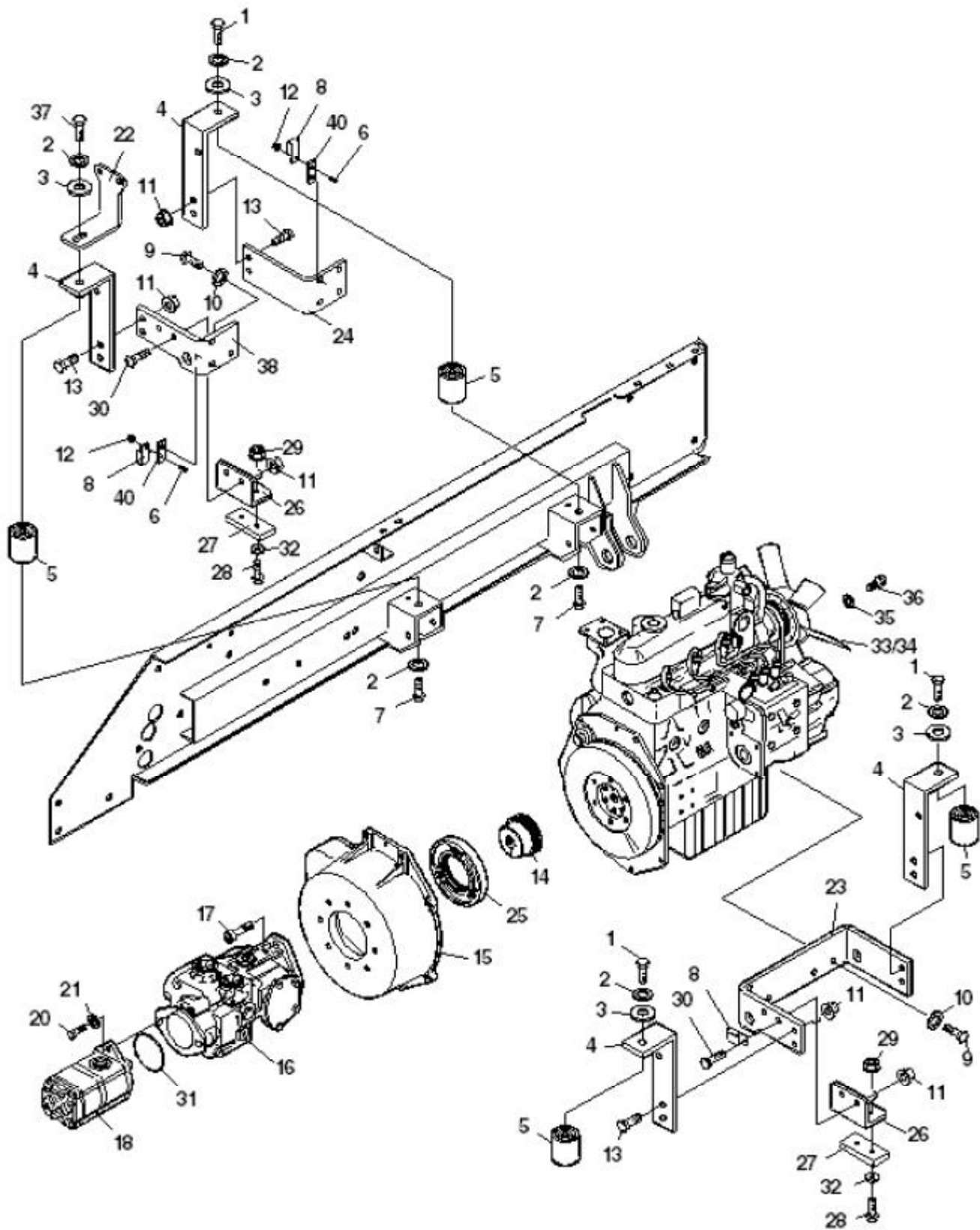

ENGINE MOUNTING

LIST OF PARTS

ITEM	RANSOMES PART NO	DESCRIPTION 	QTY	REMARKS
2-1	64123-73	BLT HEX 1/2-1.5 X 1	4	(SEAL KIT 2208182-01)
2-2	GSF2163L	LOCKWASHER 1/2	8	
2-3	A159905	33/64 X 1 1/4 X 12GA WASHER	4	
2-4	2202064	BRKT-ENG MOUNTING	4	
2-5	48380	MOUNT, ISOLATION	4	
2-7	A102109	BLT-HEX11/2-13X3/4	4	
2-9	450214	BLT-METRIC M10-1.25X25	10	
2-10	450412	LOCKWASHER	10	
2-11	450379	LOCKNUT NYLON MI 0-1.5	12	
2-13	450030	HEX BOLT MI 0-1.5 X 40	8	
2-14	2208063	COUPLING-15 TOOTH	1	
2-15	2208048-01	BELL HOUSING	1	
2-16	2208192	PUMP	1	
2-17	64189-8A	BLT HEX SOC 1/2-13 X 1.25	2	
2-18	2208182	PUMP-2 SECTION	1	
2-20	64123-50	BLT HEX 3/8-16 X 1	2	
2-21	GSF2163J	LOCKWASHER	2	
2-23	MBG1549B	BRKT-MOTOR, LH	1	
2-24	MBG1911A	ENGINE BRACKET RH REAR	1	
2-25	2208048-02	DISC	1	
2-26	2202269	BRKT-BUMPER MOUNTING	2	
2-27	2208195	BUMPER-DECK STOP	2	
2-28	450000	BOLT-MET M6-1 .00X25	4	
2-29	450377	LOCKNUT-NYL M6-1 .00	4	
2-30	450215	SCREW-M10X30	4	
2-31	158061-04	O-RING	1	
2-32	GSF2152A	WASHER	4	
2-33	2203099A	FAN SPACER	1	
2-34	2720495	FAN, 16.5"	1	
2-35	450410	S.L.WASHER M6	4	
2-36	450172	SCREW M6 X25 HEX HD	4	
2-38	MBG1912A	ENGINE BRACKET RH FRONT	1	

* Not Illustrated

RANSOMES
AR 250
SERIES: VN

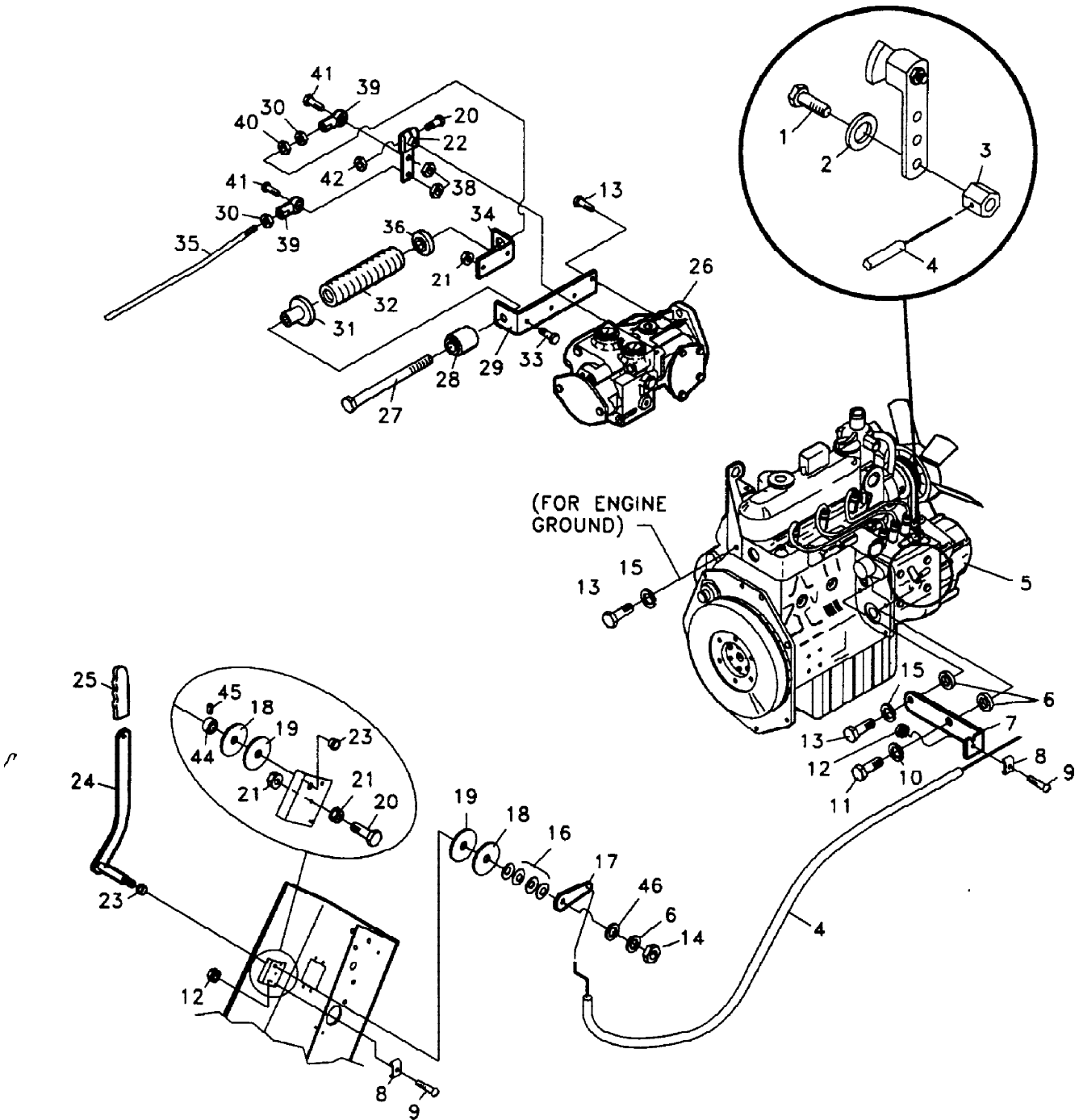

ITEM	RANSOMES PART NO	DESCRIPTION	QTY	REMARKS
		GB		
3-1	64123-59	BLT-HEX 5/16-24 X 1/2	1	
3-2	A159401	WASHER	1	
3-3	172084	CLAMP THROTTLE	1	
3-4	W148057-03	CABLE, THROTTLE	1	
3-5	A682182	ENG-KUBOTA V15O5B-15	1	
		KUBOTA ENGINE NUMBERS:		
	12251-4301-0	IN-LINE FUEL FILTER		
	15221-4308-0	CARTRIDGE FUEL FILTER		
	68371-5121-0	ELECTRIC FUEL PUMP		
	16271-3209-0	OIL FILTER		
3-6	A159926	WASHER	3	
3-7	172085	BRACKET-THROTTLE	1	
3-8	W022372	B & S CABLE CLAMP	2	
3-9	64152-49	10-24 x 3/4 MACH SCREW	2	
3-10	450412	LOCKWASHER	1	
3-11	450214	BLT METRIC MI 0-1.25 X 25	1	
3-12	A139325	NUT HEX #10-24 KEPS	2	
3-13	450191	BLT M8-1 .25 X 20	3	
3-14	A139303	5/16-18 HEX LOCKNUT	1	
3-15	64006-02	LOCKWASHER	2	
3-16	H083031	CONICAL SPRING WASHER	4	
3-17	172088	THROTTLE	1	
3-18	64163-18	WASHER	2	
3-19	64163-25	WASHER	2	
3-20	64123-69	BLT-HEX 5/6-18 X 1-1/2	3	
3-21	A139301	NUT-WLF 5/16-18	6	
3-22	172364A	ARM-CONTROL HD	1	
3-23	W118047-02	BUSHING FLIP-LOK 1/2	2	
3-24	176102	S THROTTLE LEVER W/LAB	1	
3-25	W038404-02	GRIP, CONTROL LEVER	1	
3-26	2208192	PUMP	1	SEE PAGE 61 FOR BREAKDOWN
3-27	A109065	BLT-HEX3/8-24X7	1	
3-28	43039A	SPACER, BELT GUIDE PLT	1	
3-29	172028	BASE-NEUTRAL RETURN	1	
3-30	GSF2052AC	NUT-HEX JAM 3/8-24	1	
3-31	43034A	BUSH, FRT-NEU-CNTRL-PLT	1	
3-32	48060-01	NEUTRAL RETURN SPRING	1	
3-*	A291079	SPRING	1	
3-33	A119003	BLT-WLF 5/16-18 x 3/4	2	
3-34	172029	BRACKET-NEUTRAL RETURN	1	
3-35	2203042	ROD-FWD/REV	1	
3-36	43035A	BUSH, REAR-NEU CTRL PLT	1	
3-38	64151-18	3/8-16 CL HEX NUT	2	
3-39	BAQ8011	BALL JOINT	2	

* Not Illustrated

RANSOMES
AR 250
SERIES: VN

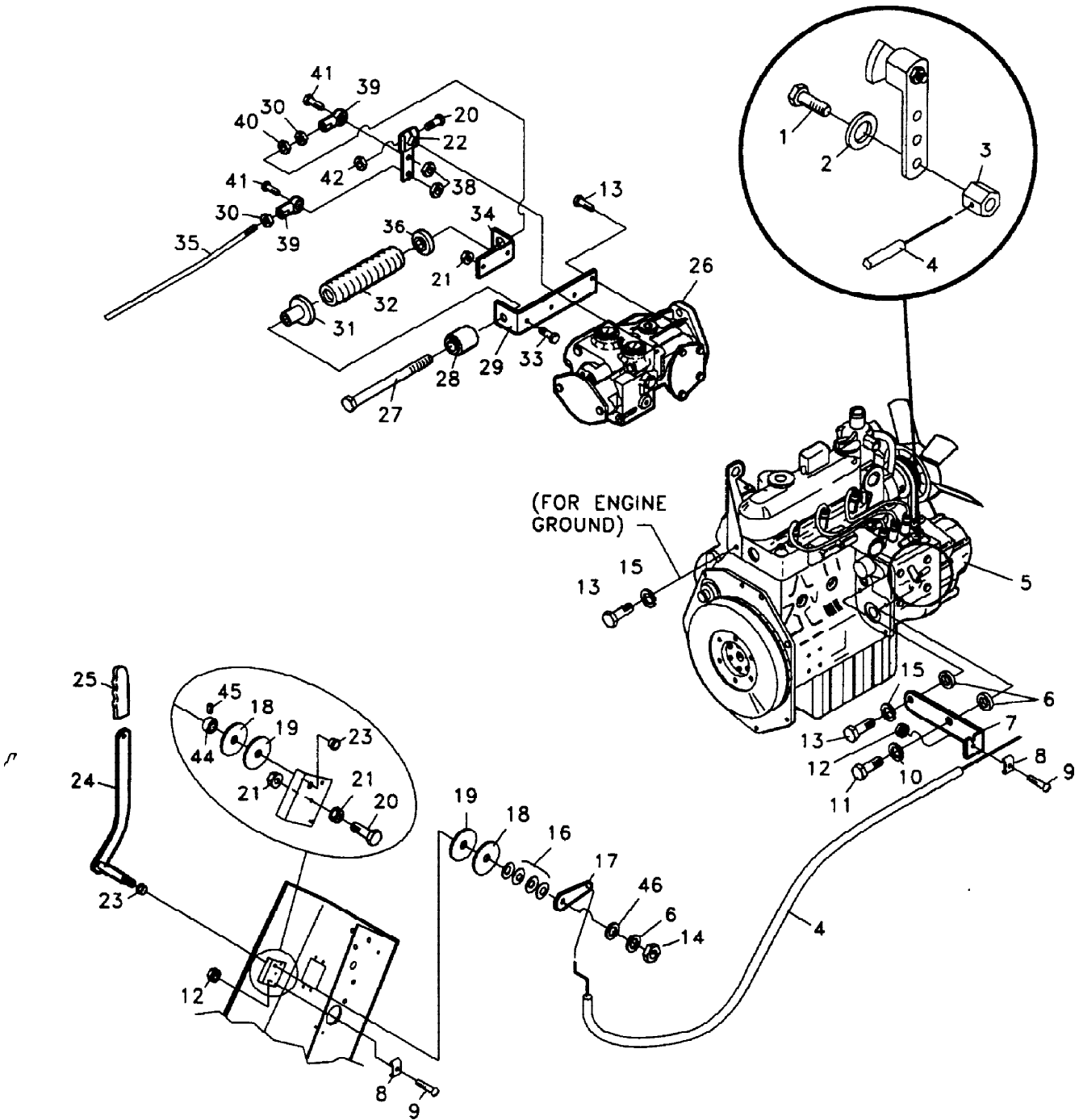

ITEM	RANSOMES PART NO	DESCRIPTION GB	QTY	REMARKS
3-40	64151-3	3/8-24 HH LOCK NUT	1	
3-41	64123-50	BLT-HEX 3/8-16 x 1	2	
3-42	64151-3	3/8-24 HH LOCKNUT	1	
3-44	W43067A	COLLAR SET	1	
3-45	A129037	SET SCREW	1	
3-46	A159905	WASHER	1	

* Not Illustrated

RANSOMES
AR 250
SERIES: VN

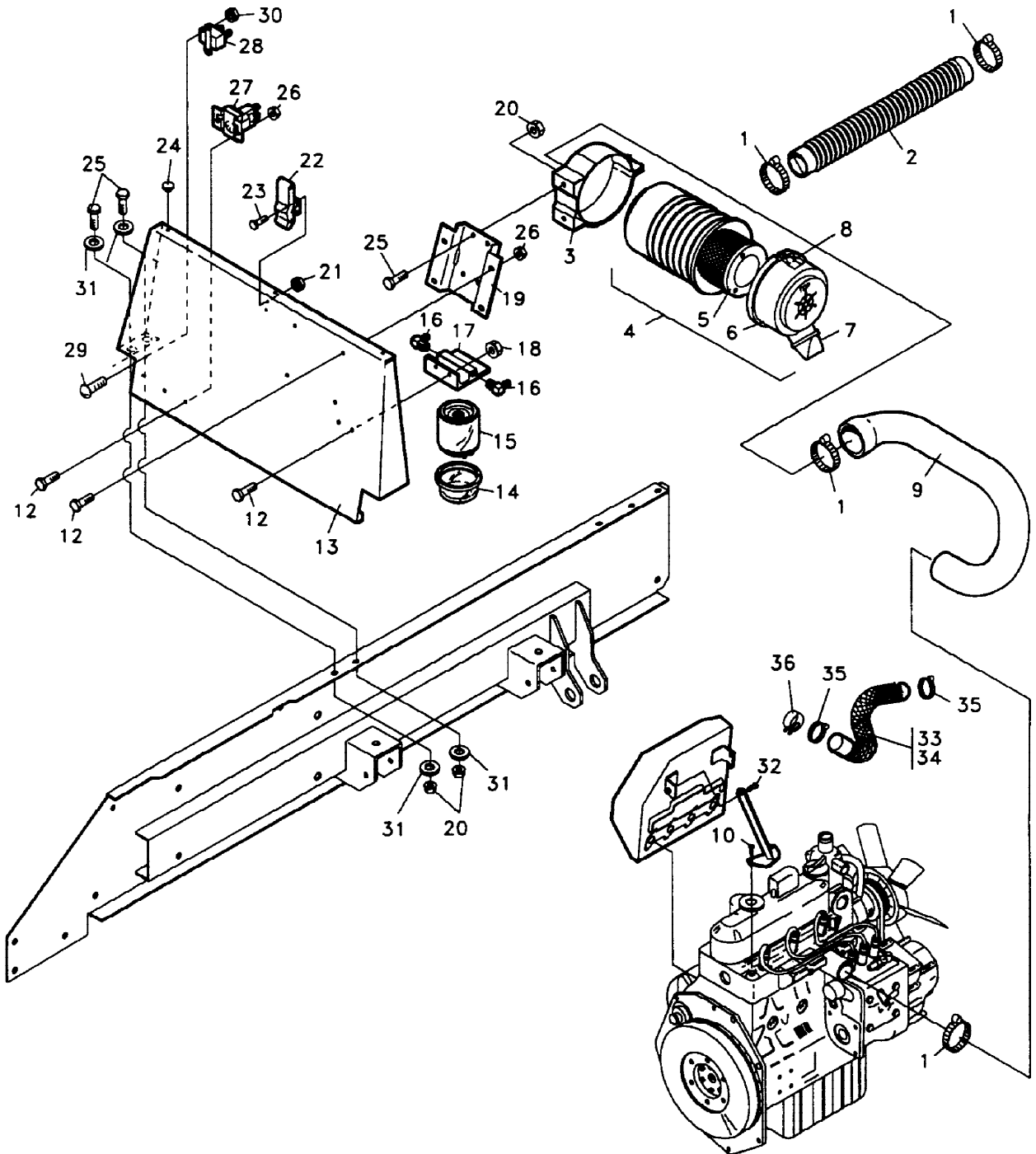

FILTER MOUNTING

LIST OF PARTS

ITEM	RANSOMES PART NO	DESCRIPTION 	QTY	REMARKS
4-1	48383	CLAMP	4	(INCLUDES ITEMS 5-8)
4-2	198069-02	S-HOSE-AIR CLAR INTAKE	1	
4-3	2198114	CLAMP-AIR CLEANER	1	
4-4	2198147	AIR CLEANER	1	
4-5	2198147-01	FILTER ELEMENT	1	
4-6	2198147-03	COVER	1	
4-7	2198147-02	VALVE-DUST UNLOADER	1	
4-8	2198147-04	S-COVER CLIP	1	
4-9	2208086	HOSE-AIR CLEANER	1	
4-10	450192	BOLT-M8-1.25X25	4	
4-12	64139-20	WIZ BOLT M6-1X16	8	
4-13	2202085A	PANEL, FRONT	1	
4-14	W178077	SIGHT BOWL	1	
4-15	W178078	FILTER-COALESCER	1	
4-16	108086-05	FITTING	2	
4-17	W178081	ASSY-FILTER HEAD	1	
4-18	450377	LOCKNUT-NYLON M6-1 .00	2	
4-19	2192276	MNT-PLASTIC AIR CLAR	1	
4-20	450378	NUT-NYL M8-1 .25	6	
4-21	64025-29	NUT-HEX #8-32 KEPS	2	
4-22	2198112	LATCH, HOOD	1	
4-23	A119114	#8-32 X 1/2 MACH SCREW	2	
4-24	2198125	BUMPER	3	
4-25	450191	BLT-MET M8-1 .25 X 20	6	
4-26	450452	WIZ NUT M6-1 .00	6	
4-27	W38665	SOLENOID	1	
4-28	A824942	BREAKER, 40 AMP	1	
4-29	A119004	#10-24 X 1/2 SCREW	2	
4-30	A139325	#10-24 KEPS NUT	2	
4-31	450390	WASHER M8	8	
4-32	450214	BOLT-MET 10-1.25 X 25	2	
4-33	2208132	EXHAUST PIPE	1	
4-35	108094-01	HOSE CLAMP .75 TO 1.75	2	
4-36	A199035	CLAMP-MUFFLER 1-1/2	1	

* Not Illustrated

RANSOMES
AR 250
SERIES: VN

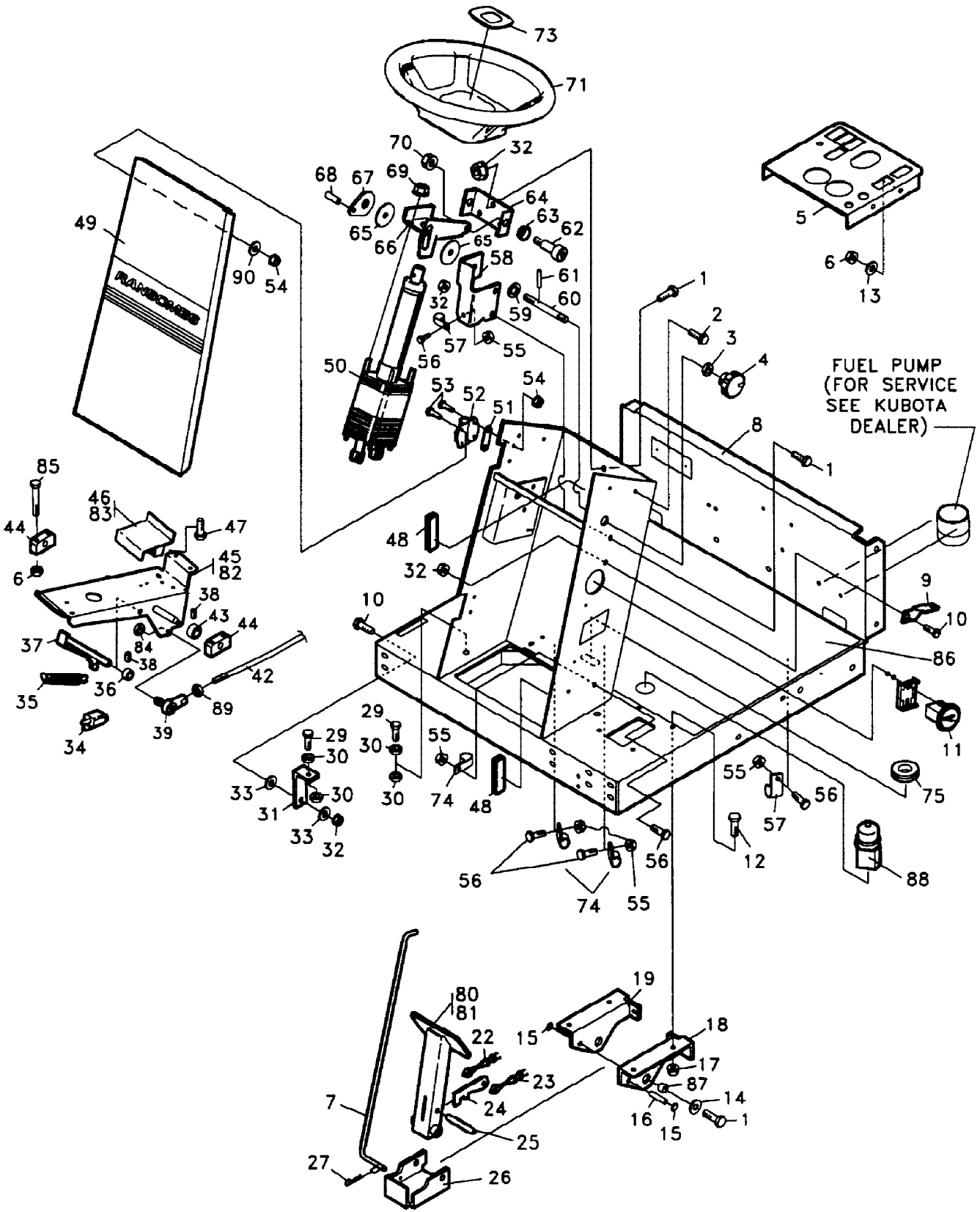

STEERING WHEEL AND PEDAL MOUNTING

LIST OF PARTS

ITEM	RANSOMES PART NO	DESCRIPTION 	QTY	REMARKS
5-1	450213	HEX BOLT MI 0-1.5 X 55	6	
5-2	450170	BOLT M6-1.00 X 16	4	
5-3	64001-8	NUT-HEX JAM 112-13	1	
5-4	W038124-01	KNOB	1	
5-5	A905024	PANEL INSTRUMENT	1	
5-6	450377	LOCKNUT NYLON M6-1 .00	9	
5-7	2203070	ROD-BRAKE RELEASE	1	
5-8	2206060	S TOWER W/LABS	1	
5-9	2202159	GUIDE-BRAKE ROD	1	
5-10	450214	BOLT M10-1.5X25	2	
5-11	A810966	HOURLMETER	1	
5-12	450191	BLT METRIC M8-1 .25 X 50	4	
5-13	450389	WASHER M6	4	
5-14	450391	WASHER M10	2	
5-15	W64175-04	PUSH NUT 3/8 DIA	2	
5-16	2203067	PIN-BRAKE	1	
5-17	450378	LOCKNUT-NYLON M8-1 .25	4	
5-18	2202149	BRKT BRAKE LH	1	
5-19	2202150	BRKT BRAKE RH	1	
5-22	W128025-04	CABLE-BRAKE	1	
5-23	W128025-03	CABLE-BRAKE1	1	
5-24	2202154	LATCH-BRAKE1	1	
5-25	2203069	PIN-BRAKE PEDAL	1	
5-26	2202148A	RELEASE-BRAKE	1	
5-27	A149000	COTTER PIN	2	
5-29	A100312	BOLT M8-1 .25 X 60	2	
5-30	450324	NUT HEX M8-1 .25	4	
5-31	2202161	BRACKET-SPEED CONTROL	1	
5-32	450379	LOCKNUT NYLON MI 0-1.5	6	
5-33	64209-07	WASHER, CONICAL MI 0	2	
5-34	38383	SWITCH	1	
5-35	48429	SPRING-EXTENSION	1	
5-36	MBF0654	COLLAR-SET 3/8 ID	2	
5-37	MBF1280	WLDMT-NEUTRAL CONTROL	1	
5-38	A129037	SETSCREW 1/4-20X114	4	
5-39	BAA0444	BALL JOINT-SPF-6S	1	
5-42	2203042	ROD-FWD/REV	1	
5-43	W43067A	COLLAR, SET PLATE	2	
5-44	MBE3498	BEARING BLOCK	2	
5-45	2196117	5 FWD/REV PED W/MAT	1	
5-46	146082	S PEDAL ADAPTER W/MAT	1	
5-47	A119037	BLT-WLF 114-20 X 1/2	2	
5-48	2208077	CATCH-MAGNET W/ADHES	2	
5-49	2216052	S TOWER COV W/LAB	1	
5-50	2208142	VALVE POWER STEERING	1	(USE SEAL KIT 2208142-01) (USE BEARING KIT 2208142-02) (USE CAP KIT 2208142-03)

* Not Illustrated

RANSOMES
AR 250
SERIES: VN

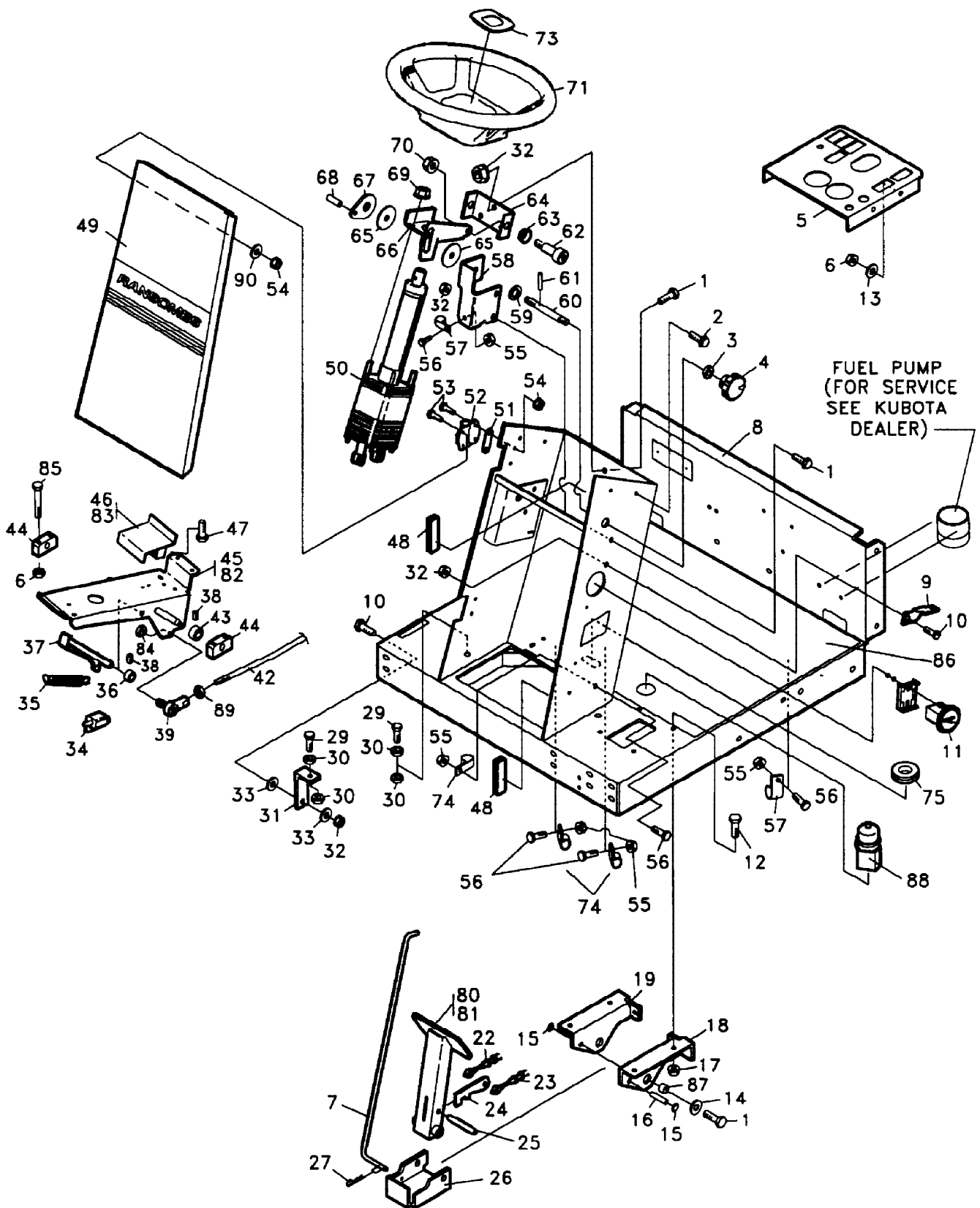

STEERING WHEEL AND PEDAL MOUNTING

LIST OF PARTS

ITEM	RANSOMES PART NO	DESCRIPTION GB	QTY	REMARKS
5-51	2202108	SPACER-TOWER HINGE	2	(INCLUDES ITEM 73)
5-52	2208076	HINGE-TOWER COVER	2	
5-53	64152-50	SCREW M5 TORX HEAD	8	
5-54	450376	LOCKNUT NYLON M5	8	
5-55	450452	WIZ NUT M6-1	5	
5-56	64139-20	WIZ BOLT M6-1 X 16	5	
5-57	48228A	CLI P	2	
5-58	172304	BRACKET-TILT WHEEL	1	
5-59	A159408	WASHER .516 ID	1	
5-60	173006	SHAFT LOCKING	1	
5-61	A141907	ROLL PIN	1	
5-62	64166-17	SHOULDER BOLT	2	
5-63	W118047-02	BUSHING, FLIP LOK 1/2	2	
5-64	172042	BRKT-STEERING	1	
5-65	178138	WASHER-FRICTION	2	
5-66	172298	SUPPORT-STEERING	1	
5-67	176100	WLDMT FRICTION WASHER	1	
5-68	A149624	ROLL PIN	1	
5-69	A139311	NUT-WLF 5/16-18	4	
5-70	GSF2080AC	LOCKNUT	2	
5-71	2198130	STEERING WHEEL	1	
5-73	839862	S-LOGO COVER	1	
5-74	H980016	CLIP	3	
5-75	W148034-01	INSUL. GROMMET 1" ID	1	
5-80	2206071	S BRAKE PEDAL W/MAT	1	
5-81	2198129	MAT-NON SKID	1	
5-82	48436	MAT, NON SKID	1	
5-83	48013-06A	MAT, NON SKID	1	
5-84	450323	NUT-HEX M6-1 .00	1	
5-85	450002	BLT-METRIC M6-1 .00 X 35	4	
5-86	2208052	MAT-PLATFORM	1	
5-87	2203046	BUSHING-BRAKE	2	
5-88	2208099	SWITCH	1	
5-89	GSF2052AC	JAM NUT 318-24	1	
5-90	450388	WASHER M5	4	

* Not Illustrated

RANSOMES
AR 250
SERIES: VN

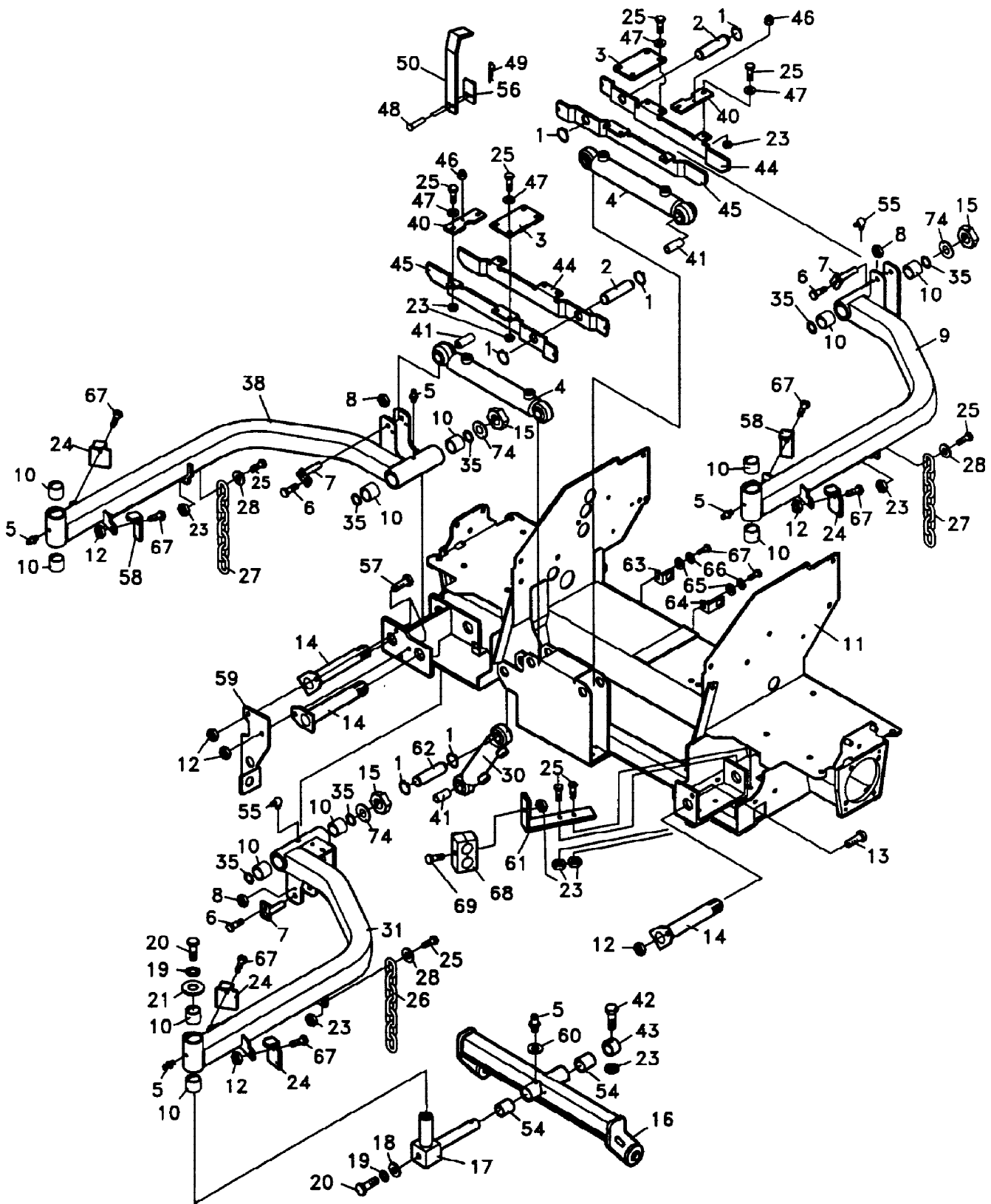

FRONT LIFT ARM MOUNTING

LIST OF PARTS

ITEM	RANSOMES PART NO	DESCRIPTION 	QTY	REMARKS
6-1	64144-13	SNAP RING	6	
6-2	2203048-02	PIN-REEL CYLINDER	2	(USE ON RH & LH UNITS)
6-3	2202170	PLATE-LIFT STOP	2	
6-4	2208151	CYLINDER-REEL, LONG	2	(USE SEAL KIT 198040-01)
6-5	GSF2540AC	ZERK GREASE FITTING	7	
6-6	64139-20	WIZ BOLT M6-1.00 X 16	3	
6-7	2206032	WLDMT-CYLINDER PIN	3	
6-8	450452	WIZ NUT M6-1 .00	3	
6-9	2206175	S-LIFT ARM, LEFT FRONT	1	(INCLUDES ITEMS 5,10 & 55)
6-10	W108003	BUSHING	12	
6-11	2206076	S FRAME FRONT W/LABS	1	
6-12	450379	LOCKNUT-NYLON MI 0-1.5	9	
6-13	450215	SCREW, M10X30 HH	1	
6-14	2206051	WLDMT-PIVOT PIN REAR	3	
6-15	A139382	NUT HEX 1-1/4-12 NYLOK	3	
6-16	2206178	S-DECK PIVOTS YOKE	3	(INCLUDES ITEMS 5, 54 & 60)
6-17	2206010	ASSY, PIVOT SHAFT	3	
6-18	A159905	WASHER	6	
6-19	GSF2163L	LOCKWASHER	3	
6-20	450241	BOLT-M12-1.75X30	6	
6-21	64163-74	WASHER	3	
6-23	450378	LOCKNUT NYL INS M8-1 .25	20	
6-24	2202209	STOP-REEL PIVOT	4	
6-25	450192	BOLT-M8-1.25X25	17	
6-26	158001-06	CHAIN 6.7 LG PLATED	1	(USE ON CENTRE UNIT ONLY)
6-27	W158001	CHAIN-7.6 LONG, 8 LINK	2	(USE ON RH & LH UNITS)
6-28	A159401	WASHER	3	
6-30	2208152	CYLINDER-REEL SHORT	1	(USE ON CENTRE UNIT ONLY)
6-*	198040-01	SEAL KIT	1	
6-31	2206176	S-LIFT ARM, CNTR FRNT	1	(INCLUDES ITEMS 5,10, & 55)
6-35	62464-4A	THRUST WASHER	AR	
6-38	2206177	S-LIFT ARM, RIGHT FRONT	1	(INCLUDES ITEMS 5 & 10)

* Not Illustrated

RANSOMES
AR 250
SERIES: VN

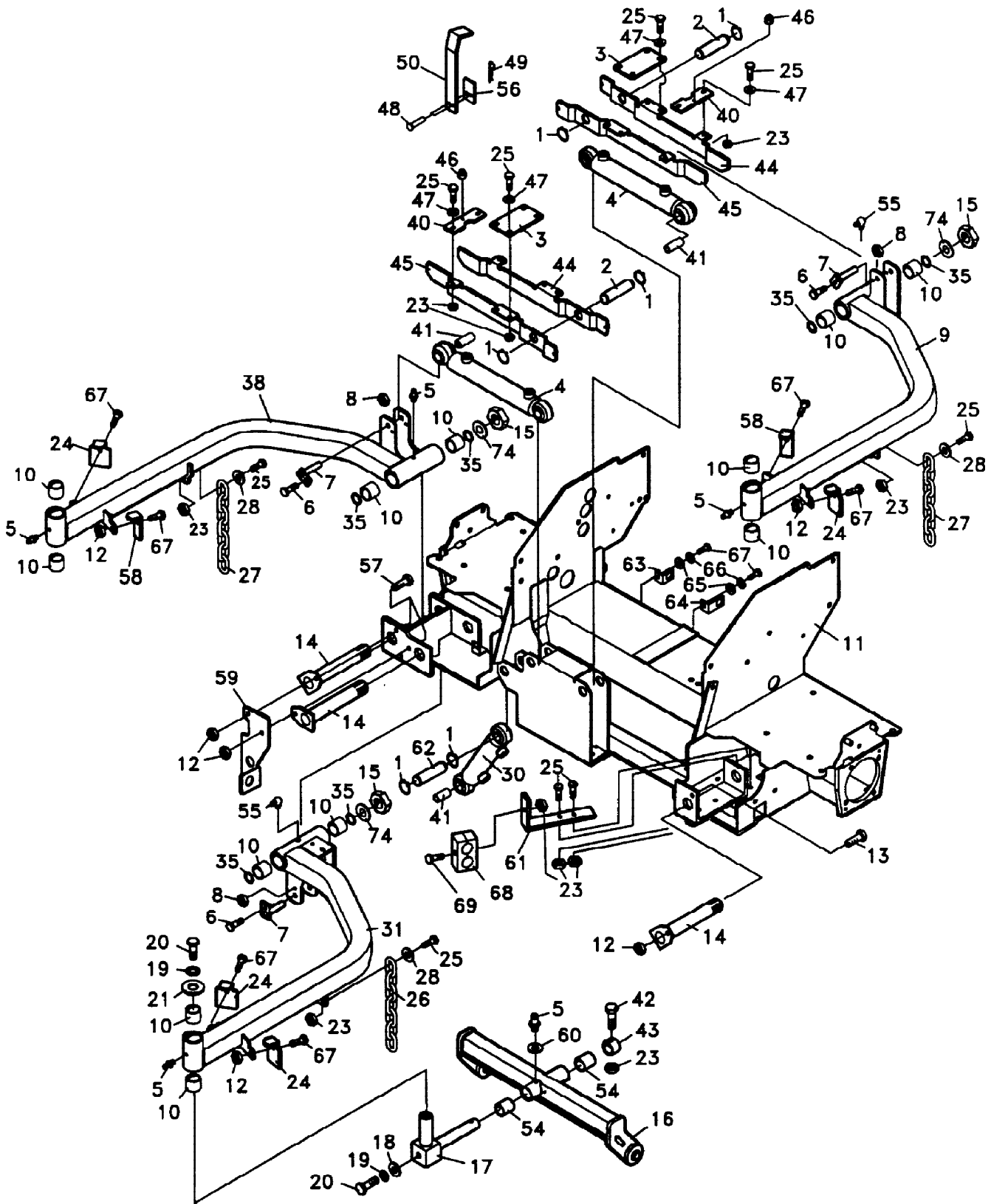

FRONT LIFT ARM MOUNTING

LIST OF PARTS

ITEM	RANSOMES PART NO	DESCRIPTION GB	QTY	REMARKS
6-40	2202171A	PLATE-LIFT STOP	2	(USE ON CENTRE UNIT)
6-41	2203083A	SLEEVE CYLINDER	3	
6-42	450018	S BLT MTRC M8-1 .25 X 50	3	
6-43	2203047	RETAINER REEL	3	
6-44	2202271	LIFT STOP-LH	2	
6-45	2202270	LIFT STOP-RH	2	
6-46	2208067	BUMPER-RUBBER	2	
6-47	450390	WASHER	12	
6-48	64188-02	CLEVIS PIN	2	
6-49	A149022	HAIRPIN COTTER	2	
6-50	2202172	LIFT LEVER-FOOT	1	
6-54	48048A	BEARING-SLEEVE	6	
6-55	35027N	ZERK GREASE FITTING	2	
6-56	2202173	PLATE-LIFT STOP BCKNG	1	
6-57	450029	BLT-METRIC MI 0-1 .50X35	2	
6-58	2202096	STOP-REEL PIVOT	2	
6-59	2202253	BRKT-BULKHEAD, FRONT	1	
6-60	GSF2152A	WSHR - .256 1D X 18 GA.	3	
6-61	2202321	BRKT-HOSE, FRONT LT	1	
6-62	2203048-03	PIN-REEL CYL 108.37 LG	1	
6-63	2202113	BRKT-HYD FTG	1	
6-64	2202112	BRKT-HYD FTG	1	
6-65	450412	LOCKWASHER M10	2	
6-66	450391	WHSR-M10	2	
6-67	450214	BOLT-MI0-1.50X25	8	
6-68	2208139	CLAMP-TUBE	1	
6-69	450020	BOLT-M8-1 .25X60	1	
6-74	GSF2150P	WASHER	3	

* Not Illustrated

RANSOMES
AR 250
SERIES: VN

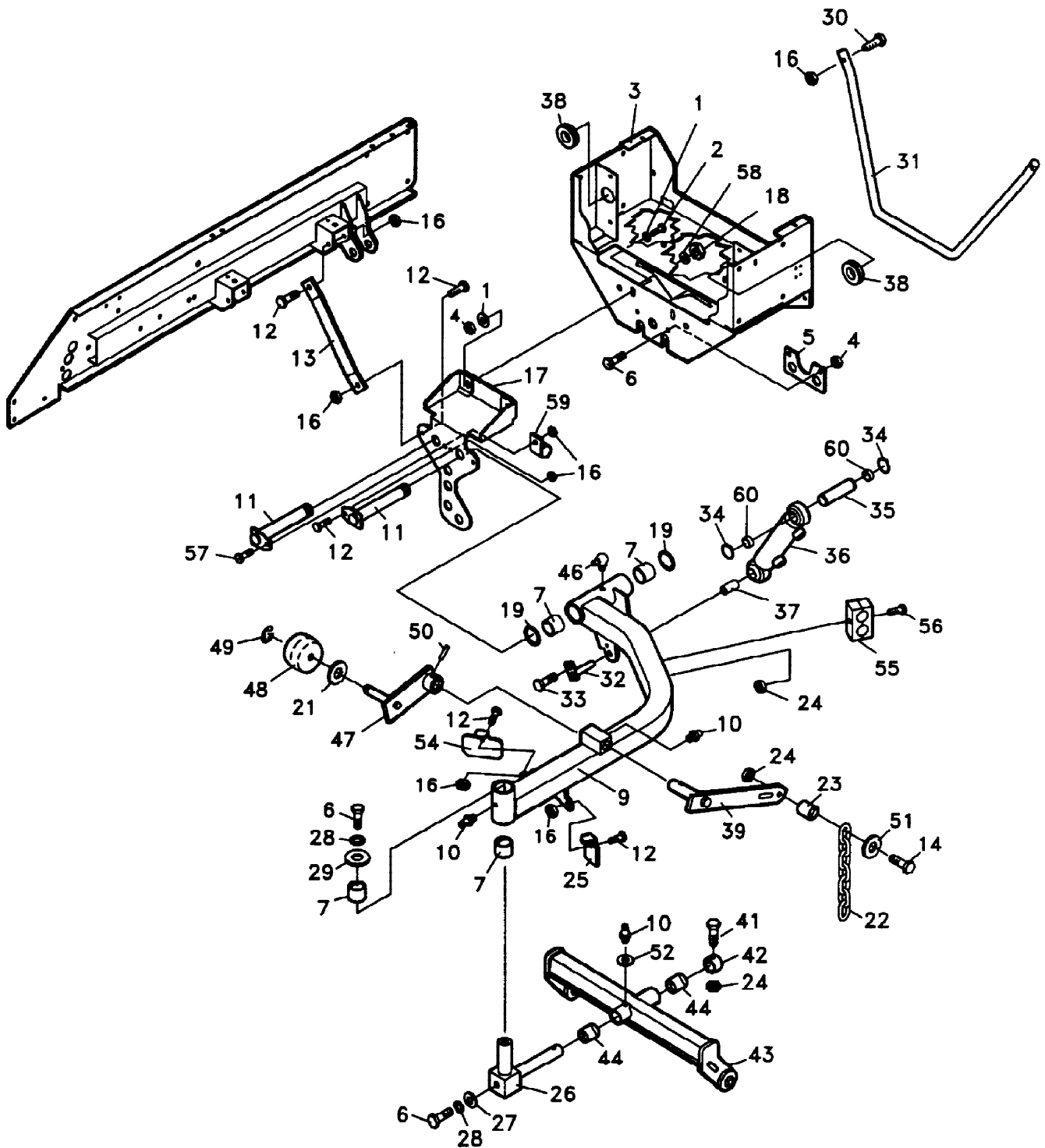

REAR LIFT ARM MOUNTING

LIST OF PARTS

ITEM	RANSOMES PART NO	DESCRIPTION 	QTY	REMARKS
7-1	450392	WASHER-M12	4	
7-2	450048	BOLT M12 x 1.75 X 40	2	
7-3	2206142	WLDMT-FRAME REAR	1	
7-4	450380	LOCKNUT-NYLON MI 2-1.75	4	
7-5	2202146	PLATE	1	
7-6	450241	BOLT M12-1.75 X 30	6	
7-7	W108003	BUSHING	8	
7-8*	2206174	S-LIFT ARM, RIGHT REAR	1	(INCLUDES ITEMS 7,10, & 46)
7-9	2206173	S-LIFT ARM, LEFT REAR	1	(INCLUDES ITEMS 7,10, & 46)
7-10	8501 ON	ZERK GREASE FITTING	6	
7-11	2206051	WLDMT-PIVOT PIN REAR	2	
7-12	450214	BOLT M10-1.5 X 25	9	
7-13	2202092A	BRACE-REAR REEL	2	
7-14	450015	BLT-METRIC M8-1.25 X 35	2	
7-16	450379	LOCKNUT NYLON M10-1.5	12	
7-17	MBG1572	BRKT-REAR ARM	1	
7-18	A139382	NUT-HEX 1-1/4-12 NYLOCK	2	
7-19	62464-4A	THRUST WASHER	AR	
7-22	W158001-05	CHAIN 6.7 LG PLATED	2	
7-23	23009A	SPACER, ENGINE MOUNT	2	
7-24	450378	LOCKNUT NYL M8-1 .25	6	
7-25	2202209	STOP-REEL PIVOT	2	
7-26	2206010	ASSY, PIVOT SHAFT	2	
7-27	A159905	WASHER	2	
7-28	GSF2163L	LOCKWASHER	4	
7-29	64163-74	WASHER	2	
7-30	450030	HEX BOLT M10-1.5 X 40	2	
7-31	2208084	GUARD 4WD HOSES	1	
7-32	2206032	WLDMT-CYLINDER PIN	2	
7-33	64139-20	WIZ BOLT M6-1 X 16	2	
7-34	64144-13	SNAP RING	4	
7-35	2203048-03	PIN-REEL CYLINDER	2	
7-36	2208152	CYLINDER-REEL SHORT	2	(USE SEAL KIT 198040-01)
7-37	2203083A	SLEEVE-CYLINDER	2	
7-38	148034-05	GROMMET-INSULATION	2	
7-39	2206168	WLDMT-CHAIN ARM LH	2	
7-40	* 2206169	WLDMT-CHAIN ARM RH	2	
7-41	450018	S BLT MET M8-1 .25 X 50	2	
7-42	2203047	RETAINER-REEL	2	
7-43	2206178	S-DECK PIVOT	2	(INCLUDES ITEMS 10, 44 & 52)
7-44	48048A	SLEEVE BEARING	4	

* Not Illustrated

RANSOMES
AR 250
SERIES: VN

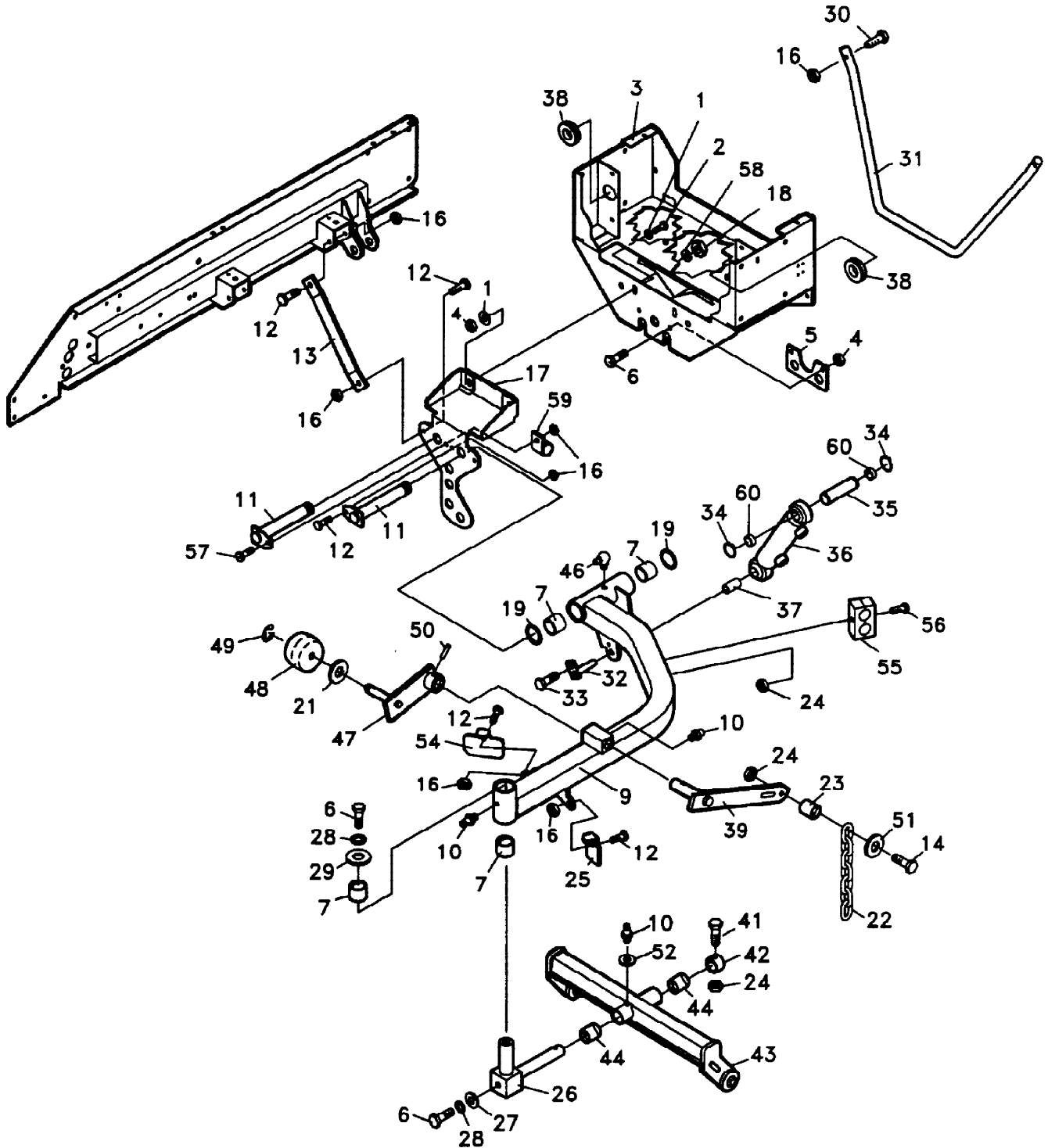

REAR LIFT ARM MOUNTING

LIST OF PARTS

ITEM	RANSOMES PART NO	DESCRIPTION GB	QTY	REMARKS
7-46	35027N	ZERK GREASE FINING	2	
7-47	2206170	WLDMT-ROLLER ARM	2	
7-48	W2198153	ROLLER, 3	2	
7-49	64144-01	SNAP RING 5/8	2	
7-50	64061-09	ROLL PIN-3/8 X 2	2	
7-51	A159401	WSHR .328 x .75 X 14 GA	2	
7-52	GSF2152A	WSHR - .256 ID x .620 ID	2	
7-54	2202267	STOP-DECK PIVOT	2	
7-55	2208139	CLAMP-TUBE	2	
7-56	450020	BOLT-M8-1 .25X60	2	
7-57	AI10406	SCREW-M10 X I .5 X 30	1	
7-58	64163-75	WASHER	1	
7-59	BAM8138PB	TUBE CLAMP	1	
7-60	2203098	SPACER-CYLINDER	2	

* Not Illustrated

RANSOMES
AR 250
SERIES: VN

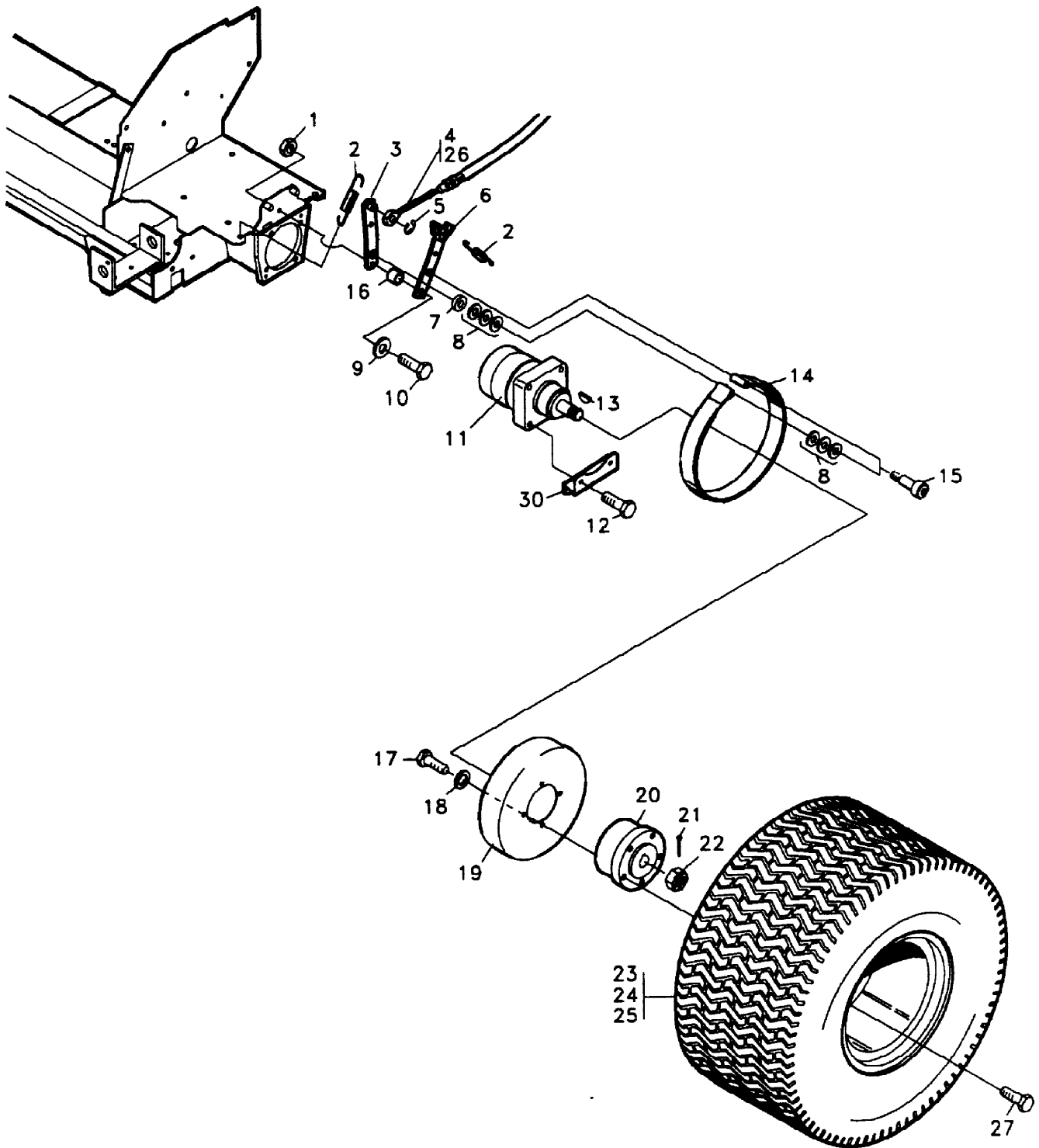

DRIVE WHEELS AND BRAKES

LIST OF PARTS

ITEM	RANSOMES PART NO	DESCRIPTION 	QTY	REMARKS	
8-1	450379	LCKNUT-NYLON INS MI 0-1.5	2	(USE FOR LEFT HAND BRAKE)	
8-2	48429	SPRING	4		
8-3	2206031	WLDMT-BRAKE ARM	2		
8-4	W128025-03	CABLE, BRAKE	1		
8-5	64144-30	SNAP RING .375	2		
8-6	2206032	WLDMT-BRAKE ARM	2		
8-7	64163-02	WASHER	2		
8-8	A159968	WASHER	12		
8-9	450391	WASHER	2		
8-10	450215	SCREW M10 X 30 HH	2		
8-11	A800698	MTR-WHL ME290208MBT	2		(USE SEAL KIT 148138)
8-12	450052	BOLT-M12-1.75X50	8		
8-13	64164-08	#1008 WOODRUFF KEY	2		
8-14	W178013	BRAKE BAND	2		
8-15	64166-7	SHOULDER BOLT	4		
8-16	MBF0838A	BUSHING - BRAKE	2		
8-17	64123-15	BLT HEX 3/8-16 X 3/4	8		
8-18	64006-04	LOCKWASHER	8		
8-19	172060	BRAKE DRUM	2		
8-20	MBG3759A	HUB	2		
8-21	451264	COTTER PIN	2		
8-22	A130291	NUT 1-20 SLOTTED TRW	2		
8-23	2208065	ASM WHL &TYRE 26.5X14-12	2		
8-24	178144-01	S RIM W/VALVE STM & CAP	AR		
8-25	2208065-02	S TIRE 26.5 X 14	AR		
8-26	W128025-04	CABLE-BRAKE	1		(USE FOR RIGHT HAND BRAKE)
8-27	A100934	BLT-WHL 1 2-20X75 60D	10		
8-30	2202247	STOP-BRAKE BAND	2		

* Not Illustrated

RANSOMES
AR 250
SERIES: VN

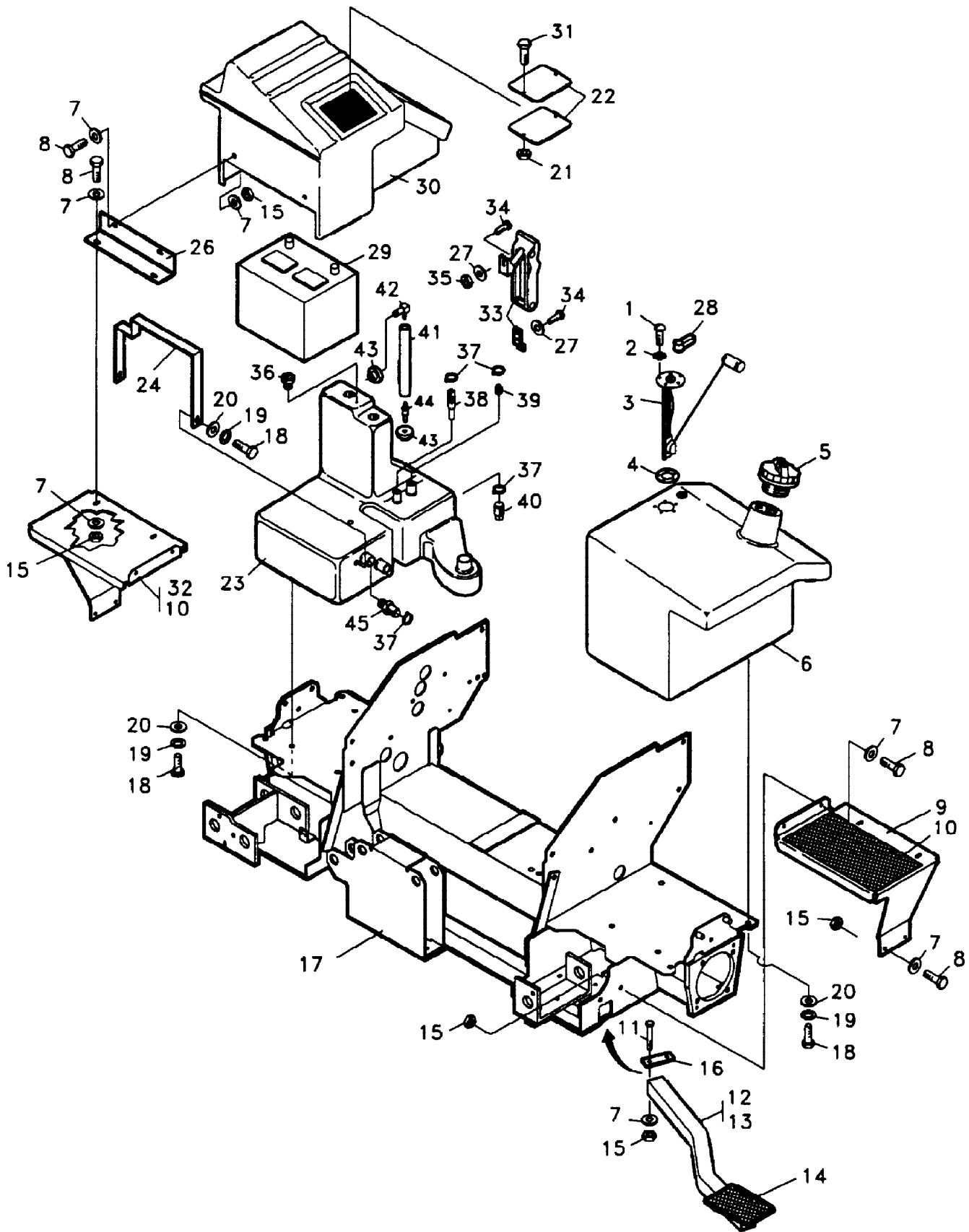

HYDRAULIC RESERVOIR AND FUEL TANK

LIST OF PARTS

ITEM	RANSOMES PART NO	DESCRIPTION GB	QTY	REMARKS	
9-1	64152-05	10-32 X 1/2 MACH SCREW	5	(USE S KEY 178105-01)	
9-2	64006-02	LOCKWASHER	5		
9-3	2208073	SENDER-FUEL LEVEL	1		
9-4	W148081	GASKET	1		
9-5	W178105	CAP-LOCKING	1		
9-6	2208027	TANK-FUEL LT FWAY	1		
9-7	450390	WASHER M8	20		
9-8	450191	BLT METRIC M8-1 .25 X 50	12		
9-9	2206063	S STEP W/MAT LH	1		
9-10	2208054	MAT-STEP	2		
9-11	450020	BOLT M8-1.25 X 60	4		
9-12	2206065	S-STEP W/MAT LH LOWER	1		
9-13	2206066	S-STEP W/MAT RH LOWER	1		(USE ON RH SIDE)
9-14	2208071	MAT-STEP	2		
9-15	450378	LOCKNUT NYLN INS M8-1.25	16		
9-16	2202138	PLATE-STEP CLAMP	2		
9-17	2206076	S-FRONT FRAME W/LABS	1		
9-18	450213	HEX BOLT MI 0-1.50 x 55	10		
9-19	450412	LOCKWASHER M10	10		
9-20	450391	WASHER M10	10		
9-21	450452	WIZNUT M6-1	2		
9-22	2202166A	PLATE-RESERVOIR COVER	2		
9-23	2208031	RESERVOIR-HYDRAULIC	1		
9-24	2202103	HOLD DOWN-BATTERY	1		
9-26	2208035	HINGE-RESERVOIR	1		
9-27	450388	WASHER	4		
9-28	2198091	BOOT, FUEL SENDER	1		
9-29	148074	BATTERY-BCI 26	1		
9-30	2208034	COVER-HYD RESERVOIR	1		
9-31	64139-20	WIZ BOLT M6-1.0 X 16	2		
9-32	2206064	S-STEP W/MAT	1		
9-33	W178142	LATCH-RUBBER	1		
9-34	64152-50	SCREW M5-.08 X 16 TORX HD	4		
9-35	450376	LOCKNUT NYLON M5-0.8	4		
9-36	148027	BREATHER VENT	1		
9-37	158065-03	CLAMP	4		
9-38	2208083	SWITCH-TEMPERATURE	1		
9-39	69051-01	PIPE PLUG	1		
9-40	108029	PLUG, MAGNETIC	1		
9-41	158122-02	TUBING-SIGHT CLASS 8"	1		
9-42	148231	S-ELBOW-90 3/16 FINING	1		
9-43	48310	S-BUSHING	2		
9-44	2208031-01	FTG-3/1 6 BARB STRAIGHT	1		
9-45	158065-03	FTG - 13/16-16/112-14	1		

* Not Illustrated

RANSOMES
AR 250
SERIES: VN

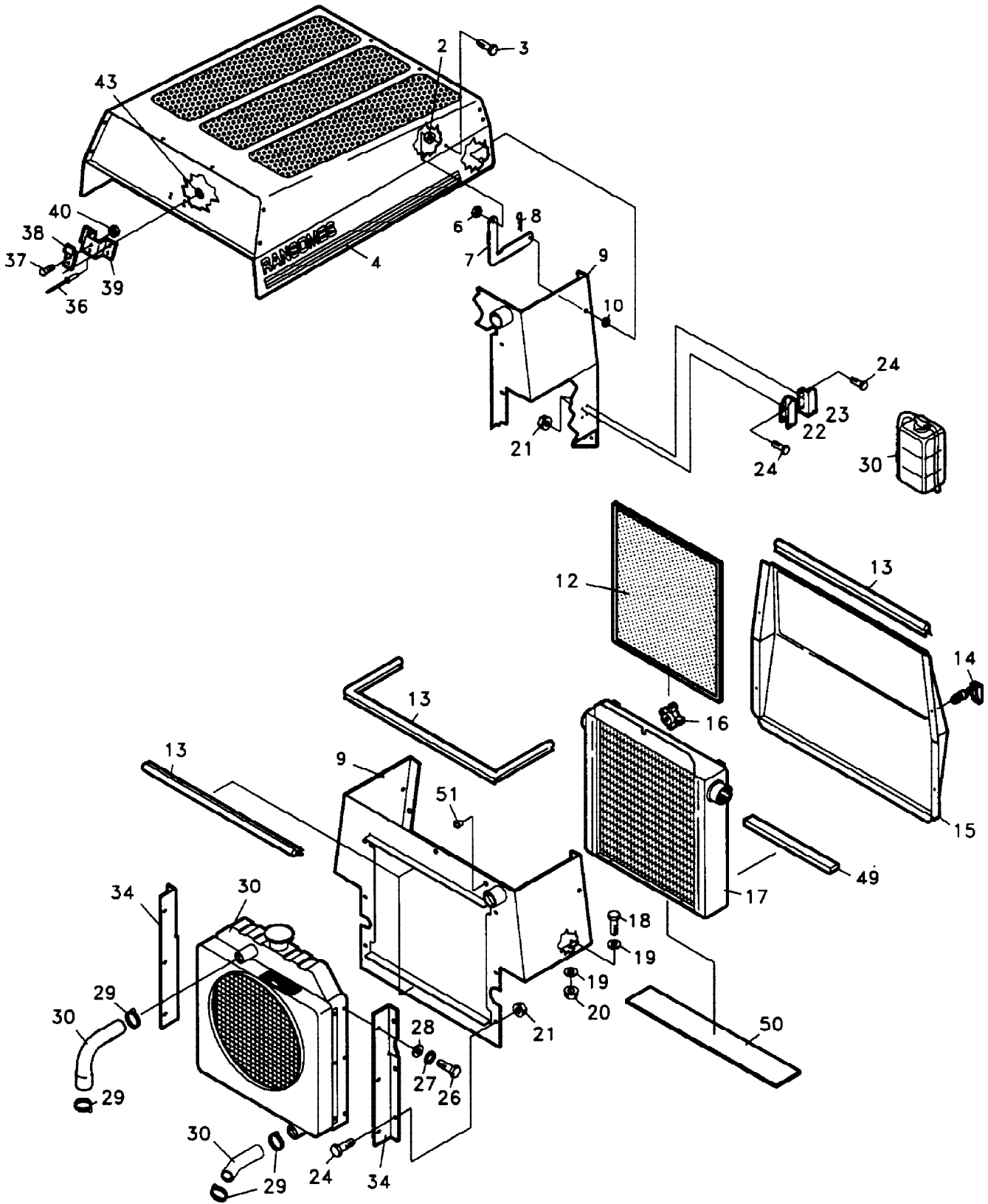

HOOD AND RADIATOR

LIST OF PARTS

ITEM	RANSOMES PART NO	DESCRIPTION GB	QTY	REMARKS
10-2	A139305	NUT-WLF1/4-20	2	
10-3	64123-114	BLT-HEX1/4-20X1	2	
10-4	2206181	S-AR250 HOOD ASSY WILA	1	
10-6	64229-01	LOCKNUT NYLON 114-20	2	
10-7	2192571	STOP-HOOD PIVOT	2	
10-8	A149000	HAIRPIN COTTER	2	
10-9	2206053B	RADIATOR PANEL	1	
10-10	118047-06	BUSHING FLIP-LOK .312 ID	2	
10-12	887888	SCREEN	1	
10-13	W108194-13	CHANNEL FLEX TRIM 41"	4	
10-14	2198084	LATCH-SWELL	4	
10-15	MBF0780	REAR PANEL	1	
10-16	W38524	KNOB	1	
10-17	2208026	OIL COOLER	1	
10-18	450191	BLT METRIC M8-1 .25 X 20	4	
10-19	450390	WASHER	8	
10-20	450378	LCKNUT NYL N INS M8- 1 .25	4	
10-21	450452	WIZ NUT M6-1	10	
10-22	142350-02	BRKT-RECOVERY TANK RH	1	
10-23	142350-01	BRKT-RECVRY TANK LH	1	
10-24	64139-20	WIZ BOLT M6-1 .0 X 16	10	
10-26	450168	BLT-METRIC M6-1 X 12	6	
10-27	64006-01	LOCKWASHER	6	
10-28	450389	WASHER	6	
10-29	108094-01	CLAMP	4	
10-30	A691069	RADIATOR	1	(KUBOTA 16296-72061)
10-34	2202144A	MNT-RADIATOR	2	
10-36	A149604	RIVET, POP IFI #64	4	
10-37	A119114	8-32 X 1/2 MACH SCREW	2	
10-38	2198112	LATCH-HOOD, FRONT	1	
10-39	2192248	BRKT-LATCH POST	1	
10-40	64025-29	NUT-HEX #8-32 KEPS	2	
10-43	64211-02	WASHER	4	
10-49	38471-09	S FOAM X 120	1	
10-50	2208080	PAD, RUBBER	1	
10-51	W118047-02	BUSHING	1	
10-52*	MBF0742	SIDE COVER RH	1	
10-53*	MBF0725A	SIDE COVER LH	1	
10-54*	MBG1787	LATCH PLATE - FLAT	2	
10-55*	MBG1788	LATCH PLATE - BENT	2	
10-56*	BAM8071	STUD	4	(FOR ITEM52, 53 TO 54,55)
10-57*	BAF8418	RETAINER	4	(FOR ITEM52, 53 TO 54,55)
10-58*	BAF8419	CLIP	4	(FOR ITEM52, 53 TO 54,55)
10-59*	450388	WASHER M5	8	(FOR ITEM 54, 55 TO 9 & FRONT PANEL)
10-60*	450376	NUT M5 STAYTITE	8	(FOR ITEM 54, 55 TO 9 & FRONT PANEL)
10-61*	450151	SCREW M5 X 16 HEX HD	8	(FOR ITEM 54, 55 TO 9 & FRONT PANEL)

* Not Illustrated

RANSOMES
AR 250
SERIES: VN

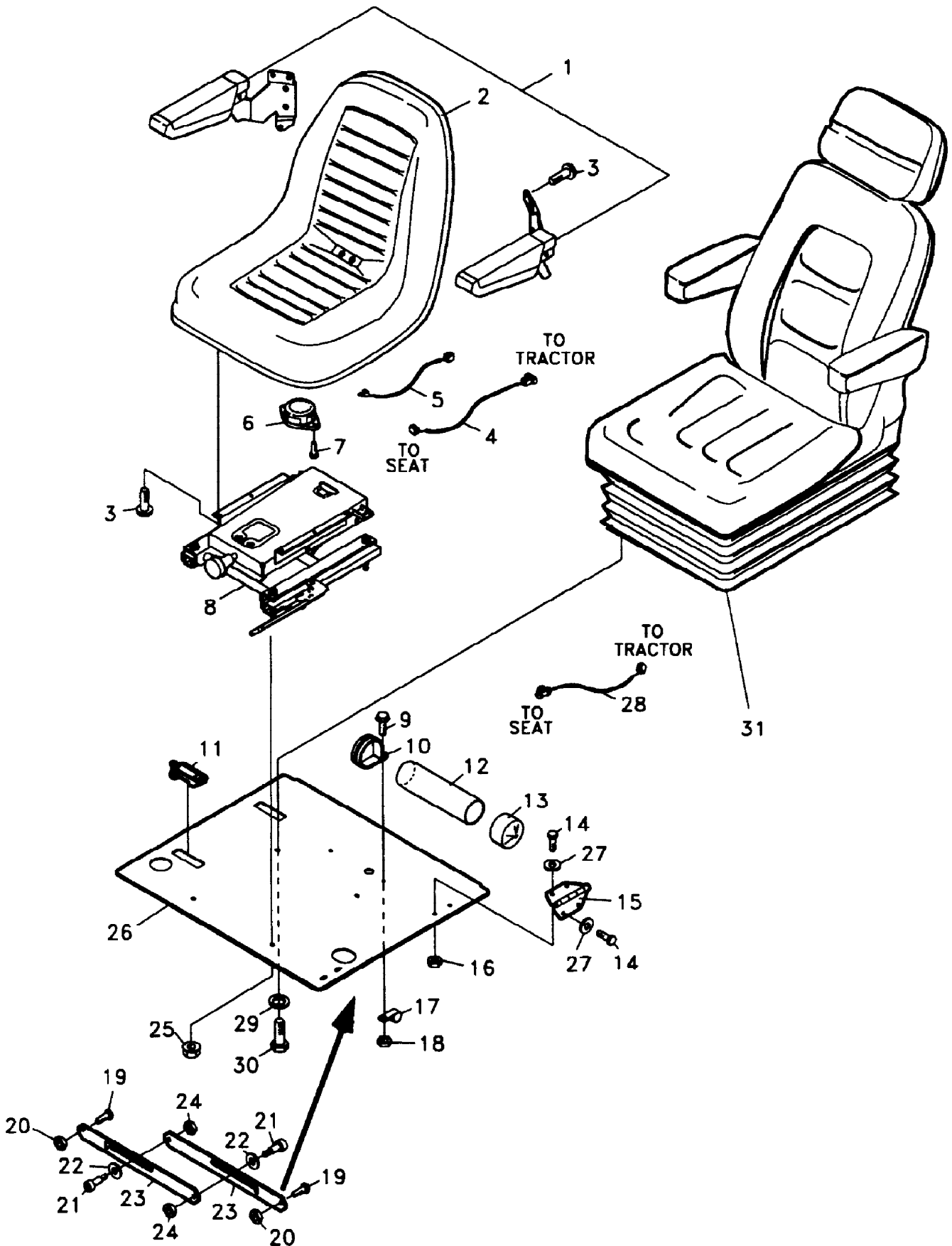

ITEM	RANSOMES PART NO	DESCRIPTION 	QTY	REMARKS
11-1	2196054	970080 INCLUDES ITEMS 1-8		
11-2	198057	SKIT-ARM REST		
	198057-01	SEAT		
		CUSHN, EDGING HWARE		
11-3	A119094	BLT-WLF 5/16 X 5/8		
11-4	2208115	WIRE-MILSCO SEAT JMPR		
11-5	158136	WIRE-SEAT SWITCH		
11-6	158135-01	SWITCH-SEAT NO		
11-7	A119037	BLT WLF 1/4-20X 112		
11-8	198058	SUSPENSION W/ ADJUST		
11-9	64139-20	WIZ BOLT M6-1.0 X 16		
11-10	38542	CLAMP-DOCUMENT TUBE		
11-11	2208075	LATCH-ADJUSTABLE LEVER		
11-12	2206184	CUT TUBE W/ LAB		
11-13	38061A	SPINDLE SHIELD		
11-14	450191	BLT-METRIC M8-1.25X20		
11-15	2208058	HINGE SEAT PLATE		
11-16	450378	LOCKNUT NYLON M8-1 .25		
11-17	H980016	CABLE CLIP		
11-18	450452	WIZ NUT M6-1 .0		
11-19	450213	HEX BOLT MI 0-1.50 X 20		
11-20	450379	LOCKNUT NYLON MI 0-1.5		
11-21	W64166-03	SHOULDER BOLT		
11-22	A159926	WASHER		
11-23	2202118	SUPPORT-SEAT		
11-24	A139322	LOCKNUT NYLON 5/16-18		
11-25	A139301	NUT WLF 5/16-18		
11-26	2206182	S SEAT PLATE W/LABS		
11-27	450390	WHSR-M8		

* Not Illustrated

RANSOMES
AR 250
SERIES: VN

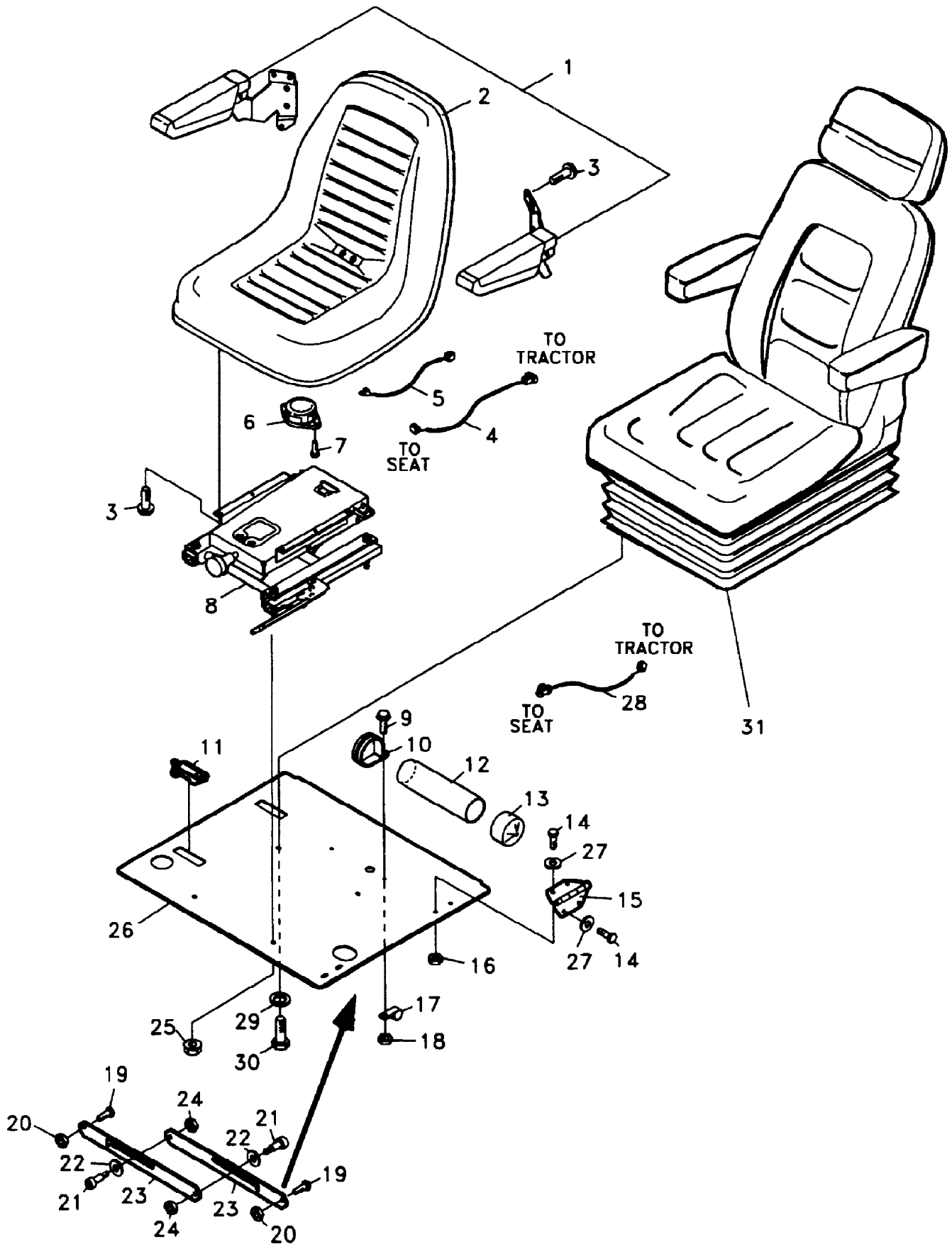

ITEM	RANSOMES PART NO	DESCRIPTION GB	QTY	REMARKS
11-28 11-29 11-30 11-31	2208116 64006-02 AI103051 A819940	970081 INCLUDES ITEMS 28-31 WIRE-GRAMMER SEAT JMPR LCKWSHR-HELICAL 5/16 SCREW-M8X25MM SEAT, GRAMMER (GREY)	1 4 4	
(SERVICE SUSPENSION W/148394, 148395, 143396, 148397)				
B C I L	148394	LOWER SEAT WELDMENT' (INCLUDES ITEMS B, C, I, & L)		
B C D J K	148395	UPPER SEAT WELDMENT (INCLUDES ITEMS B, O, D, J & R)		
A THRU K	148396	DELUX SEAT/SPRING SHAFT		
N THRU P	148397	SEAT ADJUSTOR		

* Not Illustrated

RANSOMES
AR 250
SERIES: VN

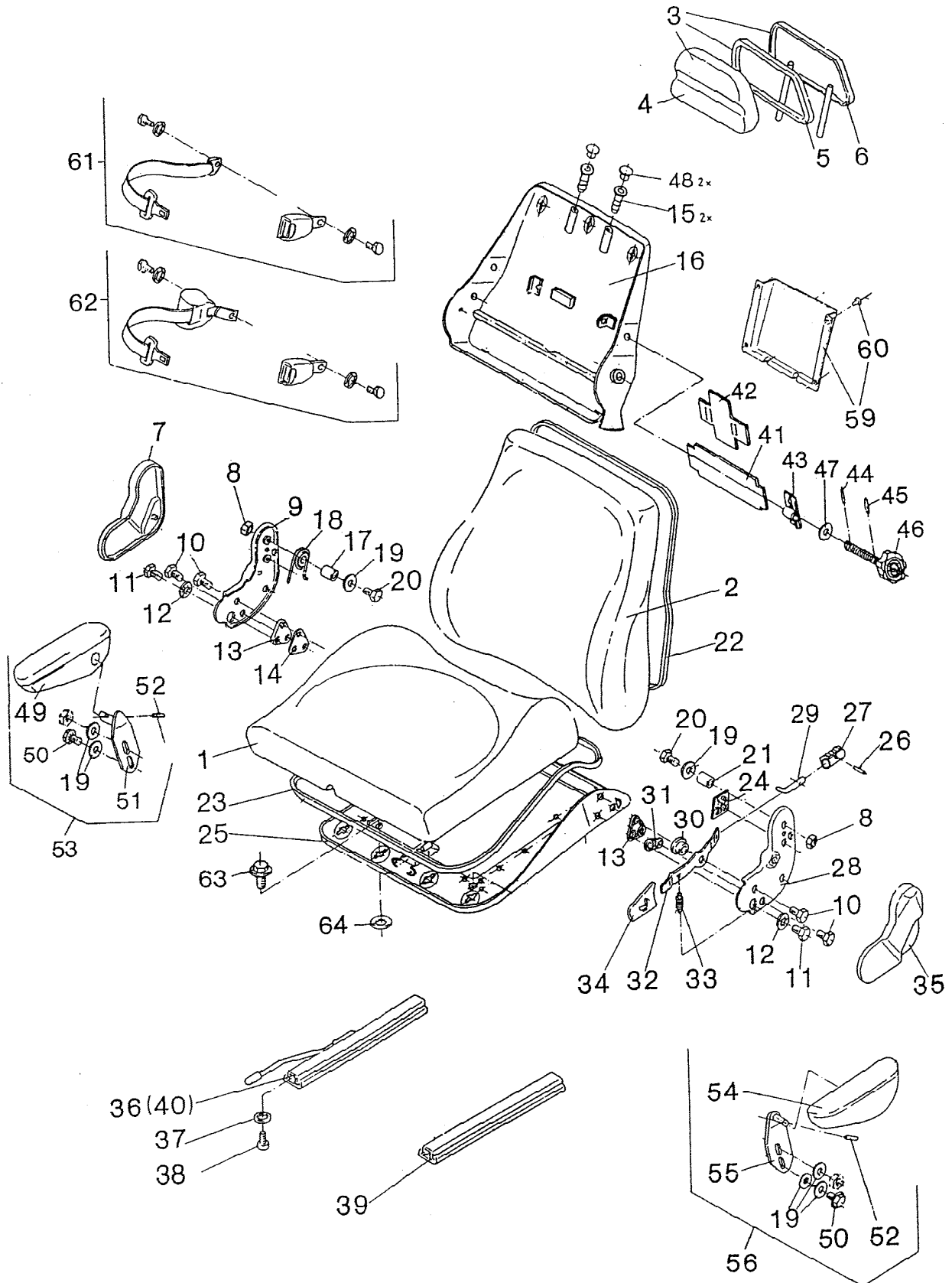

ITEM	RANSOMES PART NO	DESCRIPTION 	QTY	REMARKS
	A819940	SEAT ASSY COMPLETE	1	INCLUDING SUSPENSION
1	A819945	SEAT CUSHION	1	
2	A819946	BACK REST CUSHION	1	
3	A819956	HEAD REST ASSY.	1	
4	A819947	HEAD REST CUSHION	1	
5	A817352	EDGE STRIP	1	
6	N/A	HEAD REST FRAME	1	
7	A819961	COVER RH	1	
8	A817337	NUT	2	
9	A817338	MOUNTING RH	1	
10	A817339	SCREW	4	
11	A817340	SCREW	2	
12	A817341	SP WASHER	2	
13	A817342	DISTANCE PLATE	2	
14	A817343	DISTANCE PLATE	1	
15	A817344	BUSH	2	
16	A819969	BACK PLATE	1	
17	A817345	TUBE	1	
18	A817346	SPRING	1	
19	A817347	WASHER	2	
20	A817348	SCREW	2	
21	A817349	TUBE	1	
22	A817350	EDGE STRIP	1	
23	A817351	EDGE STRIP	1	
24	A817353	DISTANCE PIECE	1	
25	A817354	SEAT PLATE	1	
26	A819965	PIN	1	
27	A819966	DETENT	1	
28	A817355	MOUNTING LH	1	
29	A819967	ROD	1	
30	A817356	BUSH	1	
31	A817357	DISTANCE PIECE	1	
32	A817335	LEVER	1	
33	A817336	SPRING	1	
34	A819986	HANDLE	1	
35	A817358	COVER LH	1	
36	A819964	RAIL WITH LEVER	1	
37	A817359	WASHER	4	
38	A817360	SCREW	4	
39	A819975	RAIL	1	
41	A817361	PLATE	1	
42	A817362	PLATE	1	
43	A819970	NUT	1	
44	A819971	PIN	1	

* Not Illustrated

RANSOMES
AR 250
SERIES: VN

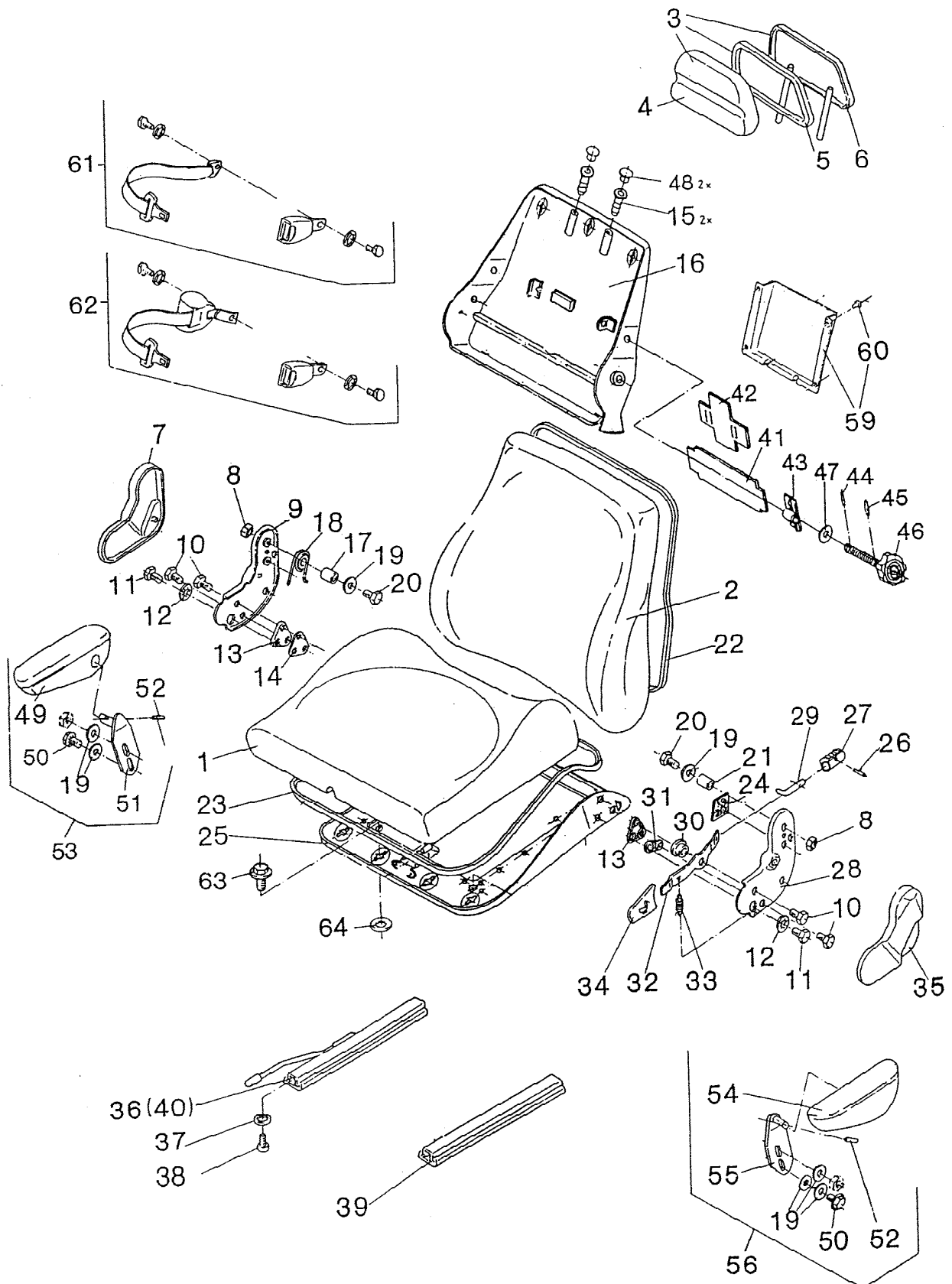

ITEM	RANSOMES PART NO	DESCRIPTION GB	QTY	REMARKS
45	A819972	PIN	1	
46	A819973	ADJUSTING SPINDLE	1	
47	A819974	WASHER	1	
48	N/A	PLUG	2	
49	A819955	ARM REST RH	1	
50	N/A	SCREW	2	
51	N/A	SUPPORT RH	1	
52	N/A	PIN	2	
53	A819985	ARM REST ASSY. RH	1	
54	A817363	ARM REST LH	1	
55	N/A	SUPPORT LH	1	
56	A819986	ARM REST ASSY. LH	1	
59	N/A	COVER ASSY	1	
60	N/A	SCREW	1	
61	N/A	SEAT BELT FIXED	1	
62	N/A	SEAT BELT REEL	1	
63	N/A	SCREW		
64	N/A	WASHER		

* Not Illustrated

RANSOMES
AR 250
SERIES: VN

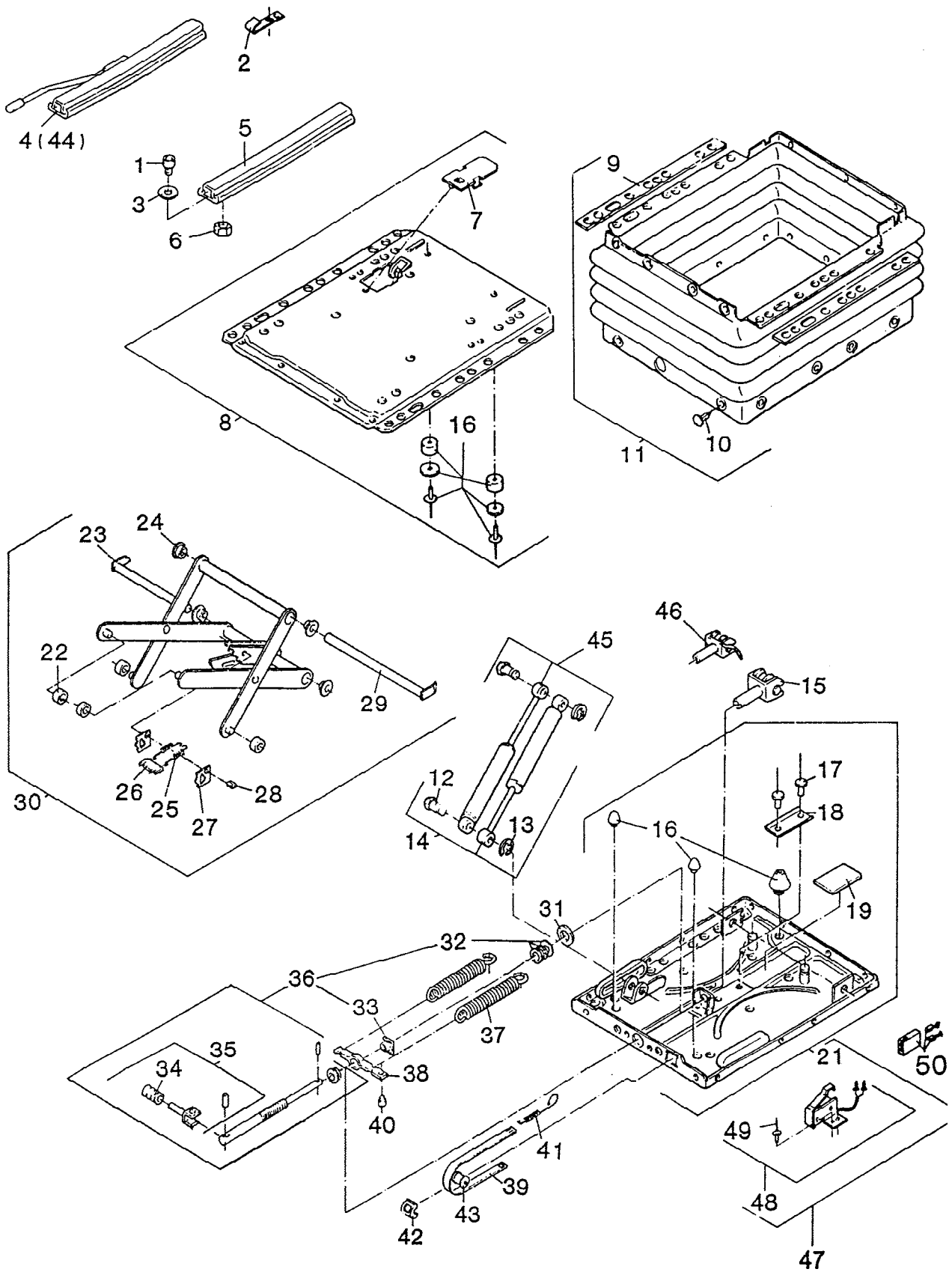

SEAT SUSPENSION BREAKDOWN GRAMMER DS85H

LIST OF PARTS

ITEM	RANSOMES PART NO	DESCRIPTION 	QTY	REMARKS
1	A817364	SCREW	6	
2	A817365	STOP	1	
3	A817366	WASHER	2	
4	A819964	SLIDE WITH LEVER	1	
5	A819975	SLIDE	1	
6	A817367	NUT	6	
7	A817368	COVER	1	
8	A817369	BASE ASSY.	1	
9	A817370	PLATE	2	
10	A819979	PIN	21	
11	A819984	GAITER ASSY.	1	
12	A817371	PIN	2	
13	A817372	E CLIP	2	
14	A819968	DAMPER ASSY	1	
16	A817373	BUFFER ASSY.	1	
17	A817374	RIVET	2	
18	A817375	RUNNER	1	
19	A817376	PLATE	1	
20	A817377	SUSPENSION ASSY.	1	
22	A817378	ROLLER	4	
23	A817379	PIN	1	
24	A817380	BUSH	4	
25	A817381	SPRING	2	
26	A817382	PLATE	1	
27	A817383	PLATE	2	
28	A817384	BOLT	1	
29	A817385	PIN	1	
30	A819990	HINGE	1	
31	A817386	WASHER	1	
32	A817387	BEARING	1	
33	A817388	NUT	1	
34	A817389	HANDLE	1	
35	A817390	LEVER ASSY.	1	
36	A819992	WEIGHT ADJUSTER	1	
37	A819941	SPRING	2	
38	A817391	SPRING HOOK	1	
39	A817392	WEIGHT INDICATOR	1	
40	A817393	STOP	1	
41	A817394	SPRING	1	
42	A817395	WINDOW	1	
43	A817396	ROLLER	1	
46	A817397	FORK	1	
47	A817398	SPRING FRAME	1	
48	A905448	MICROSWITCH	1	
49	A817399	SCREW	2	
50	A817400	CONNECTOR	1	

* Not Illustrated

**RANSOMES
AR 250
SERIES: VN**

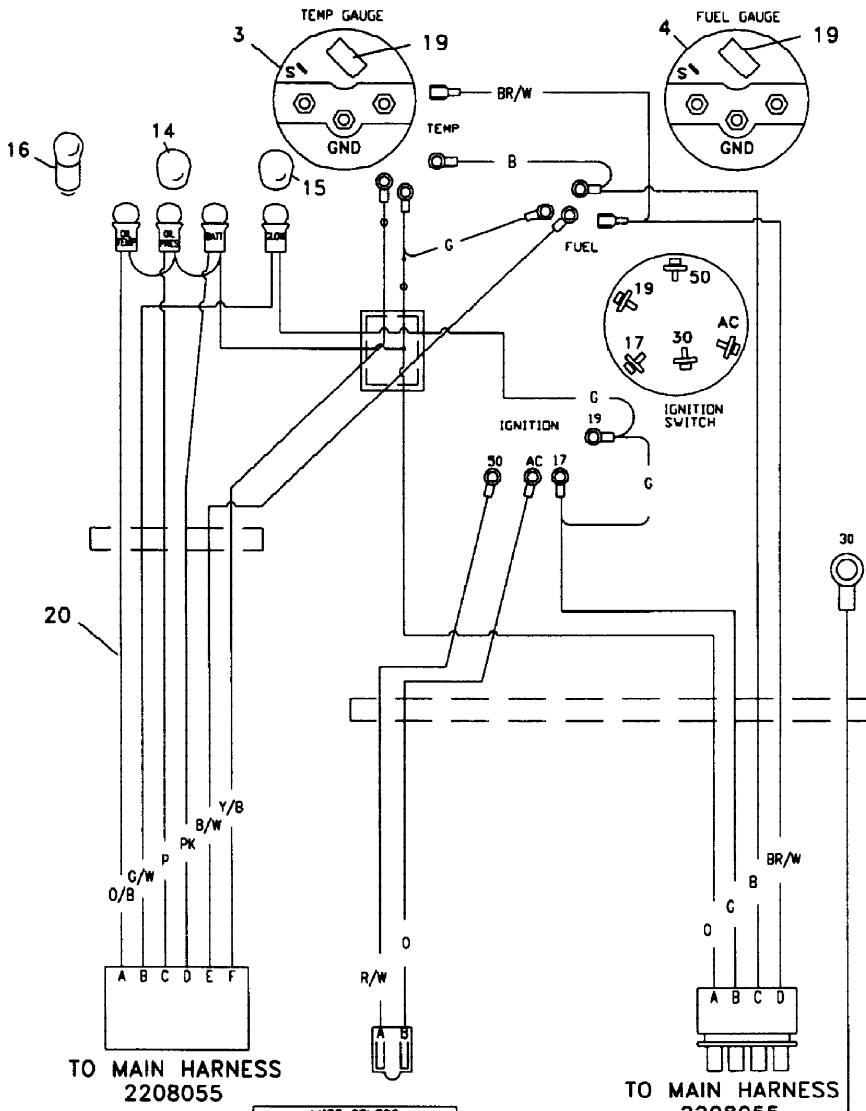

WIRE COLORS			
O	ORANGE	R/W	RED AND WHITE
B	BLACK	B/W	BLACK AND WHITE
R	RED	BL/W	BLUE AND WHITE
G	GREEN	BL/Y	BLUE AND YELLOW
P	PURPLE	G/W	GREEN AND WHITE
PK	PINK	BR/W	BROWN AND WHITE
GY	GRAY	LB/W	LIGHT BLUE AND WHITE
BR	BROWN	GR/W	GREEN AND WHITE
DB	DARK BLUE	Y/B	YELLOW AND BROWN
LB	LIGHT BLUE	Y/BR	YELLOW AND BROWN
W/R	WHITE AND RED	Y/R	YELLOW AND RED
W/B	WHITE AND BLACK	O/B	ORANGE AND BLACK
W/BL	WHITE AND BLUE	G/Y	GREEN AND YELLOW
GY/B	GRAY AND RED	R/B	RED AND BLACK
GY/BL	GRAY AND BLACK	R/Y	RED AND YELLOW
BY/BL	GRAY AND BLUE		

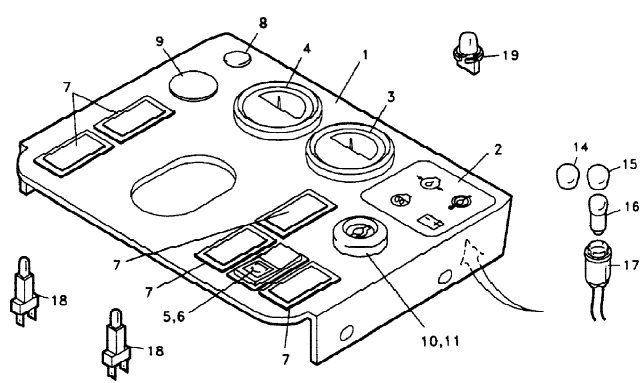

ITEM	RANSOMES PART NO	DESCRIPTION GB	QTY	REMARKS
	A905024	INCLUDES ALL ITEMS LISTED WITH THE EXCEPTION OF ITEM 20.		
12-1	178092-01	INSTRUMENT PANEL	1	
12-2	178092-02	WARN BANK SHELL PLATE	1	
12-3	178092-03	WATER TEMP GA #06347	1	
12-4	178092-04	FUEL GAUGE #06339-01	1	
12-5	2208066-01	CUTTER SWITCH	1	
12-6	178092-21	RD MOWER DECK LENS	1	
12-7	178092-13	SINGLE SWITCH BLANK	5	
12-8	178092-17	5/8" HOLE PLUG	1	
12-9	178092-18	1.0" HOLE PLUG	1	
12-10	*	KUBOTA KEY SWITCH	1	
12-11	*	KUBOTA KEYS	1	
12-14	178092-07	S AMBER BULB FILTER	1	
12-15	178092-08	5 RED BULB FILTER	3	
12-16	178092-06	S 12 VOLT LIGHT BULB	4	
12-17	178092-09	S DBLE WIRE LIGHT SOC	AR	
12-18	178092-22	S LIGHT FOR ROCKER	AR	
12-19	178092-05	SNGL GA LT SOC W/LAMP	AR	
12-20	2208056	HARNESS-INSTRUMENT PNL	1	
		* SEE KUBOTA DEALER FOR REPLACEMENTS		

* Not Illustrated

RANSOMES
AR 250
SERIES: VN

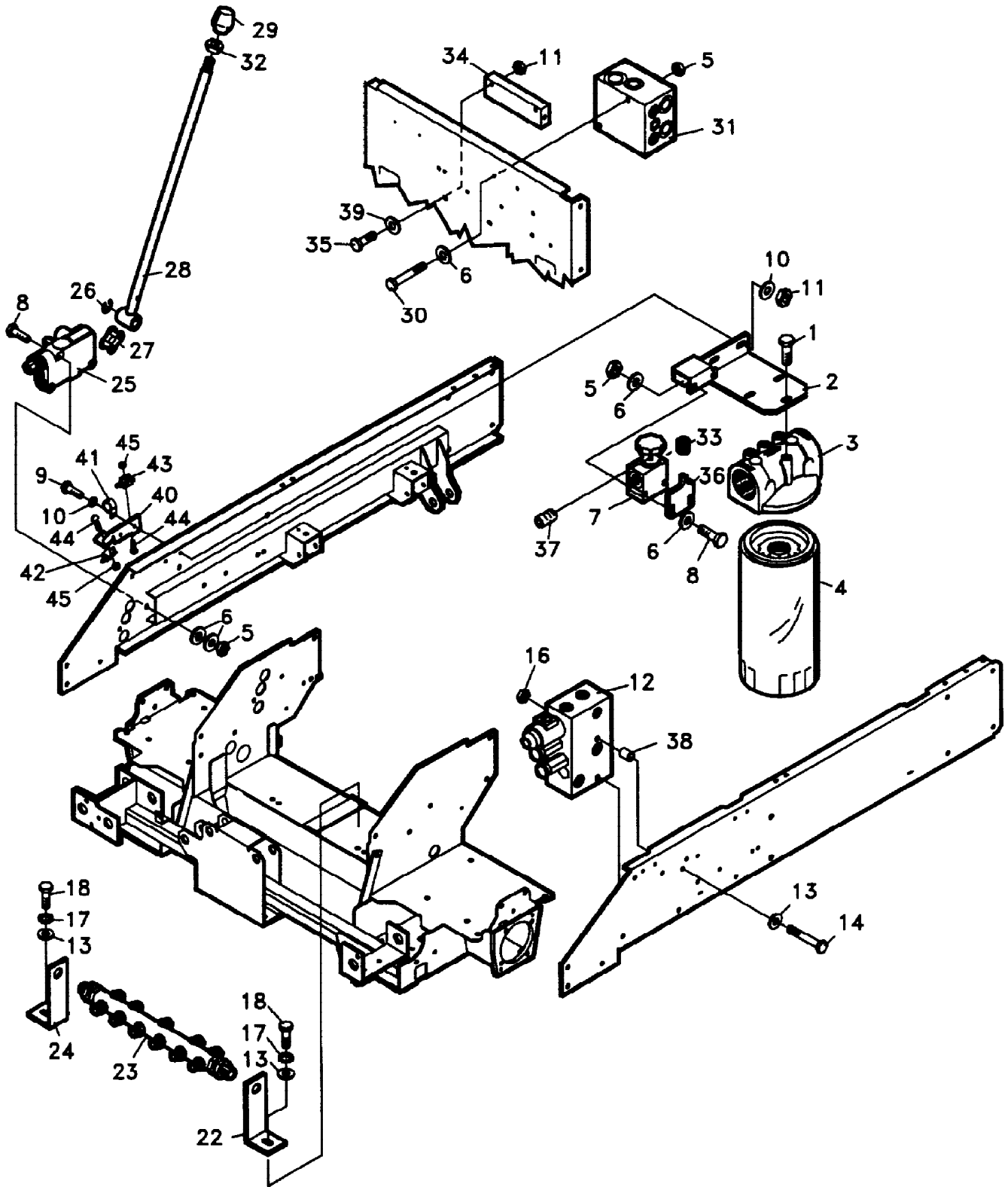

HYDRAULIC VALVE MOUNTING

LIST OF PARTS

ITEM	RANSOMES PART NO	DESCRIPTION 	QTY	REMARKS
13-1	A119003	BLT-WLF 5/16-18 X 3/4	3	
13-2	2202091	BRKT-FILTER	1	
13-3	2208038	FILTER HEAD-SPIN ON	1	
13-4	W178025	FILTER-SPIN ON	1	
13-5	450377	LOCKNUT NYLON M6-1 .0	6	
13-6	450389	WASHER-M6	10	
13-7	2208046	VALVE BLCK-BACK PRESS	1	
13-8	450005	HEX BOLT M6-1 .0 X 50	4	
13-9	450191	BLT METRIC M8-1 -25 X 20	2	
13-10	450390	WASHER-M8	4	
13-11	450378	LOCKNUT NYLON M8-1 .25	4	
13-12	2198235	VALVE-DECK	1	
13-13	450391	WASHER-M8	4	
13-14	450043	BOLT-M10X120,HEXHD	2	
13-16	450379	LOCKNUT-NYL MI 0-1.5	2	
13-17	450412	LOCKWASHER	2	
13-18	450214	BOLT M10-1.5 X 25	2	
13-22	2202114	BRKT-RETURN VALVE LH	1	
13-23	2208028	MANIFOLD-RETURN	1	
13-24	2202115	BRKT-RETURN VALVE RH	1	
13-25	2208144	LIFT VALVE	1	(SEAL KIT 148023-01) (DETENT KIT 148023-02) (PILOT CHECK KIT 148023-03)
13-26	64144-30	SNAP RING 3/8	1	
13-27	W148062	MASTER LINK #50 CHAIN	1	
13-28	2206026	WLDMT-LIFT HANDLE	1	
13-29	W068156A	HANDLE KNOB, BLACK	1	
13-30	450026	BLT-METRIC 6-1.00 X 100	2	
13-31	2208191	VALVE-4WD AR 250	1	(SEAL KIT 2208191-01)
13-32	450332	NUT-HEX JAM, 3/8-1 6	1	
13-33	2208085	SPRING-COMPRESSION	1	
13-34	2208051	MANIFOLD-LIFT	1	
13-35	AI003083	BOLT M8-1 .25 X 40	2	
13-36	2202211	STOP-BACKPRESSURE	1	
13-37	64044-17	SCREW-SET	1	
13-38	2203095	SPACER	1	
13-39	450390	WASHER-M8	2	
13-40	2202308	BRKT-SWITCH MNTG	1	
13-41	H980016	CABLE CLIP 3/4	1	
13-42	W38382	SWITCH-N.O..	1	
13-43	38383	SWITCH-N.C.	1	
13-44	A119004	10-24X112 MACH SCREW	4	
13-45	A139325	NUT-HEX #10-24 KEPS	4	

* Not Illustrated

**RANSOMES
AR 250
SERIES: VN**

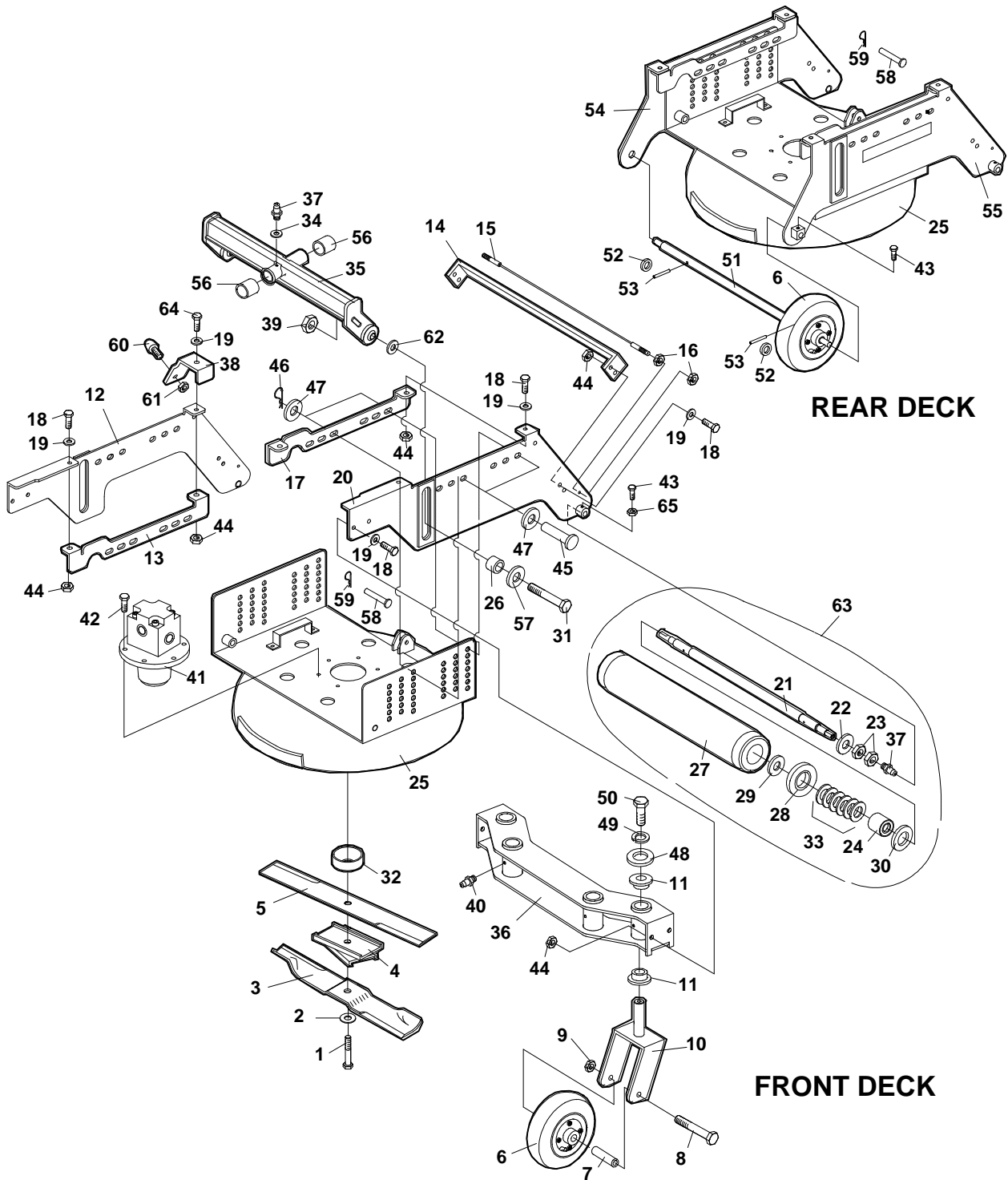

DETAIL

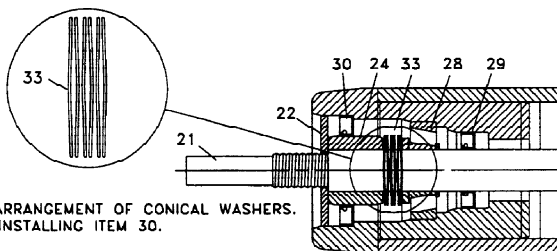

NOTE STACKING ARRANGEMENT OF CONICAL WASHERS.
INSTALL BEFORE INSTALLING ITEM 30.

ITEM	RANSOMES PART NO	DESCRIPTION 	QTY	REMARKS
14-1	64123-211	BLT-HEX 5/8-18 X 1-3/4	1	
14-2	64209-03	SPRING WASHER	1	
14-3	112243-05	BLADE 22.00 OFFSET LIFT	1	
14-4	2198192	SADDLE-BLADE	1	
14-5	2192502-03	BLADE-CUTTER AR250	1	
14-6	2208159	ASM-WHEEL 8X300-4	2	
	2208159-01	• TYRE - 8 X 300 - 4	1	
	2208159-02	• RIM	1	
	2188123-03	• BEARING	1	
14-7	A907929	SPACER-YOLK	2	
14-8	450063	BOLT M12 X 140 HEX HD	2	
14-9	450380	NUT, M12, STAYTITE	2	
14-10	2206164	WLDMT-YOKE, AR DECK	2	
14-11	48053-07	BEARING-FLANGED BRONZE	4	
14-12	2206199.2	WLDMT-SIDE PLATE, FRT LH	1	
14-13	2202242	BRKT-SIDEPLATERH	1	
14-14	2202235	CROSSBAR	1	
14-15	2208018-01	CABLE-SCRAPER 656 LG	1	
14-16	450323	NUT-HEX M6-1	4	
14-17	2202241	BRKT-SIDE PLATE LH	1	
14-18	450215	SCREW, M10 - 1.5 X 30 HH	11	
14-19	450391	WHSR-MIO	12	
14-20	2206200.2	WLDMT-SIDE PLATE, FRT RH	1	
14-21	2203012	SPINDLE 22IN	1	
14-22	2202010	SHIELD-ROLLER	2	
14-23	A130116	NUT M16	4	
14-24	2203022	SLEEVE-ROLLER	1	
14-25	2206205	ROTARY DECK	1	
14-26	2203087	SPACER-DECK	2	
14-27	2206165	ASM-SMOOTH ROLLER 4 IN	1	
14-28	H002701	BREARING	2	
14-29	2208011-02	SEAL-OIL 1.375 X .750	2	
14-30	2208011-03	SEAL-OIL 2.000 x 1.250	2	
14-31	64123-206	BLT-HEX 5/8-11 X4-1/2	2	
14-32	142108	CAP-SPINDLE	1	
14-33	A292134	DISC SPRING	12	

* Not Illustrated

**RANSOMES
AR 250
SERIES: VN**

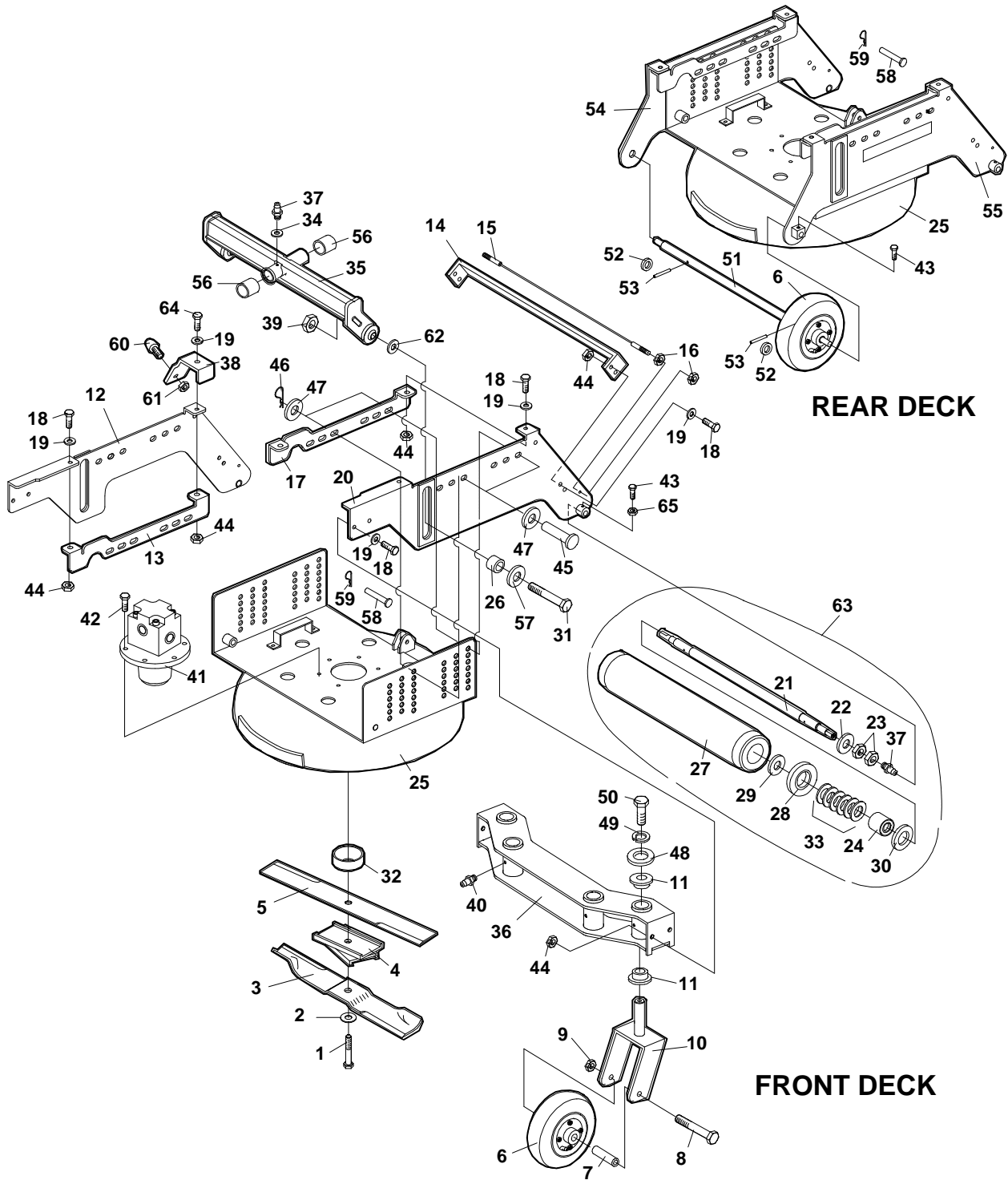

DETAIL

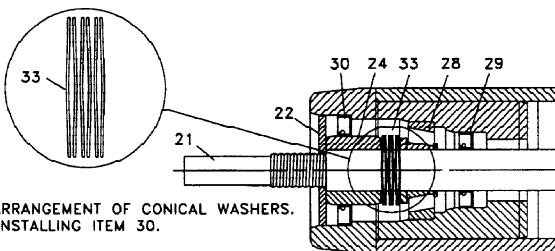

NOTE STACKING ARRANGEMENT OF CONICAL WASHERS.
INSTALL BEFORE INSTALLING ITEM 30.

ITEM	RANSOMES PART NO	DESCRIPTION 	QTY	REMARKS
14-34	GSF2152A	WSHR-.2561D x .620D	1	(INCLUDES ITEMS 34, 37 & 56) (INCLUDES ITEMS 11 & 40) (2208157-01 SEAL KIT) (2208157-02 RELIEF VALVE)
14-35	2206178	S-DECK PIVOT	1	
14-36	2206202	S-YOKE PIVOT	1	
14-37	A299301	LUBRICATOR	3	
15-38	2202307	BRACKET-BUMPER MOUNTING	1	
14-39	64229-06	LOCK NUT-NYLON 5/8-11	2	
14-40	GSF2540AC	LUBRICATOR	2	
14-41	2208229	MOTOR-HYDRAULIC DECK	1	
14-42	64197-005	BLT-TDFM 3/8-1 6X1 -1/4	6	
14-43	64205-001	BLT METRIC M8-1 .25X1 5	4	
14-44	450379	LOCKNUT-NYLON M8-I .5	12	
14-45	64188-04	PIN, CLEVIS 1/2 X 2-5/8	4	
14-46	A149022	HAIR PIN COTTER	4	
14-47	A159905	33/64 X 1 -1/4X1 2GA WASH H	8	
14-48	64163-53	WASHER .391X1.5OX9GA	2	
14-49	450412	LOCKWASHER M1O	2	
14-50	450213	BLT METRIC M8- 1 .50X20	2	
14-51	2203086	SHAFT-WHEEL	1	
14-52	64163-71	WSHR-.762X1-114X.250	2	
14-53	64176-03	PIN, SPIRAL ROLL	2	
14-54	2206198.2	WLDMT-SIDE PLATE RH	1	
14-55	2206218.2	WLDMT-SIDE PLATE LH	1	
14-56	48048A	SLEEVE BEARING	2	
14-57	64163-76	WSHR-1-3/4 x 13/16 x 9/64	2	
14-58	64188-14	SPRING CLEVIS 3 /8 X -7/16	1	
14-59	A149000	HAIRPIN COTTER	1	
14-60	523126	BUMPER-RUBBER	1	
14-61	A139322	LOCK NUT-NYLON 5/16-18	1	
14-63	2206195	S-SMOOTH ROLLER 22"	1	
14-64	450029	BLT-METRIC MI 0-1 .50X35	1	
14-65	450324	NUT M8 - 1.25	4	

* Not Illustrated

**RANSOMES
AR 250
SERIES: VN**

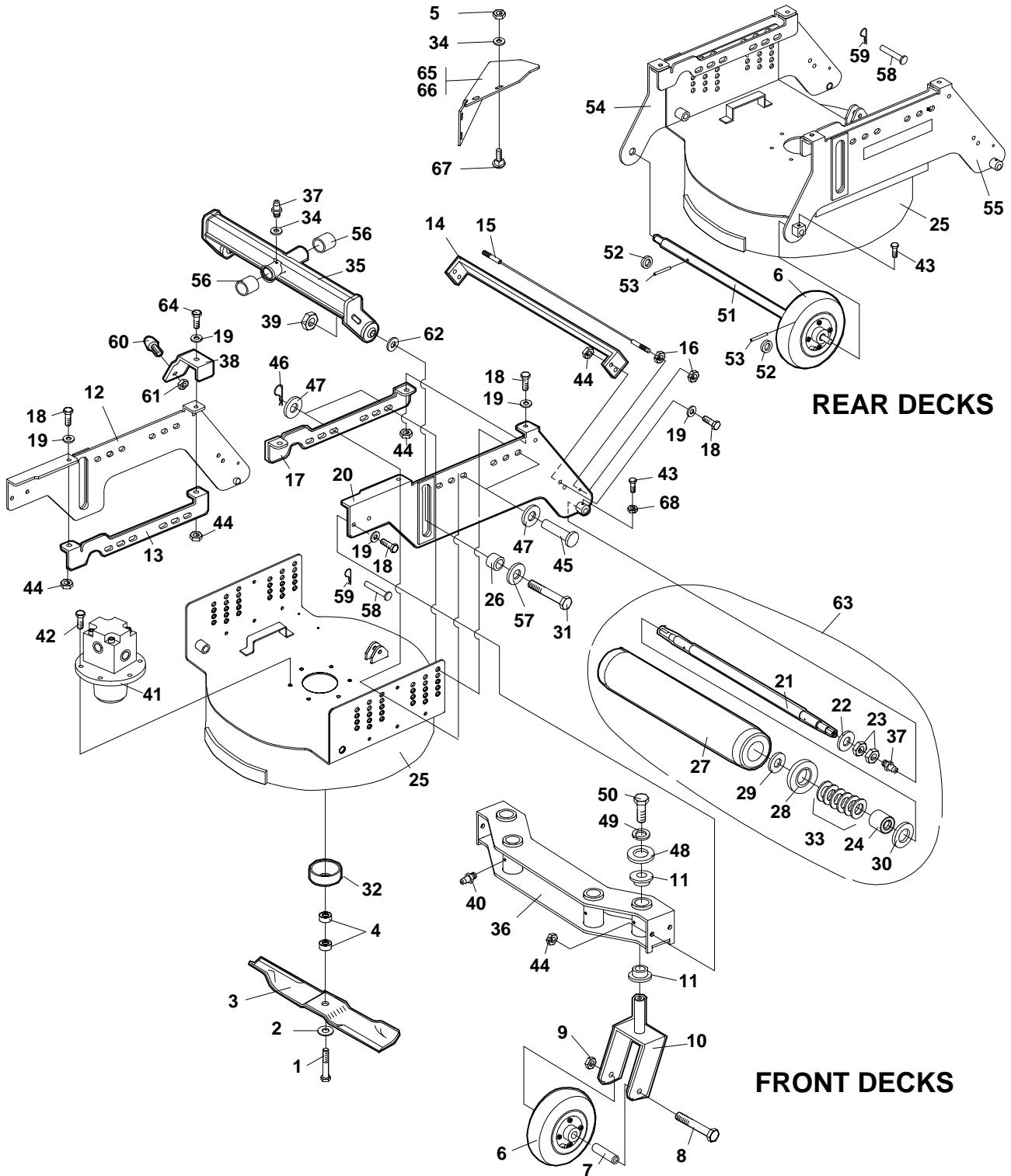

DETAIL

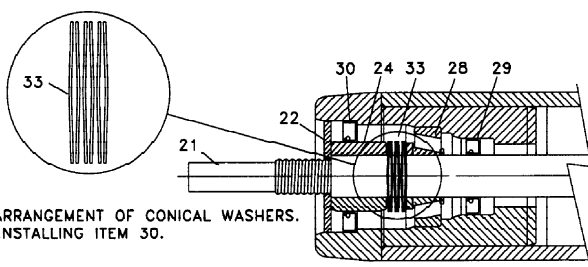

NOTE STACKING ARRANGEMENT OF CONICAL WASHERS.
INSTALL BEFORE INSTALLING ITEM 30.

SIDE DISCHARGE DECK

LIST OF PARTS

ITEM	RANSOMES PART NO	DESCRIPTION 	QTY	REMARKS
16-1	64123-211	BLT-HEX 5/8-18 X 1-3/4	1	
16-2	64209-03	SPRING WASHER	1	
16-3	112111-05	BLADE 22.00 OFFST HLFT	1	
16-4	64163-12	.635/.640X1.0X.25 WASH	2	
16-5	64229-03	LOCK NUT-NYLON 3/8-16	4	
16-6	2208159	ASM-WHEEL 8X300-4	2	
	2208159-01	• TYRE-8X300-4	1	
	2208159-02	• RIM	1	
	2188123-03	• BEARING	1	
16-7	2203097	SPACER-YOKE	2	
16-8	64123-166	BLT-HEX 1/2-13X5-1/2	2	
16-9	64229-05	1/2-13 NYLON LOCK NUT	2	
16-10	2206164	WLDMT-YOKE, AR DECK	2	
16-11	48053-07	BEARING-FLANGED BRNZE	8	
16-12	2206199.2	WLDMT-SIDE PLATE,FRT RH	1	
16-13	2202242	BRKT-SIDE PLATE RH	1	
16-14	2202235	CROSSBAR	1	
16-15	2208018-01	CABLE-SCRAPER 656 LG	1	
16-16	64207-06	NUT-HEX M6-1	4	
16-17	2202241	BRKT-SIDE PLATE LH	1	
16-18	A110406	SCREW,M10X1.5X30 HH	11	
16-19	64251-004	WHSR-M10	12	
16-20	2206200.2	WLDMT-SIDE PLATE,FRT LH	1	
16-21	2203012	SPINDLE 22 IN	1	
16-22	2202010	SHIELD-ROLLER	2	
16-23	64244-02	HEX JAM NUT M16-2.0	4	
16-24	2203022	SLEEVE-ROLLER	1	
16-25	2206217	S-AR250 SD DECK	1	
16-26	2203087	SPACER-DECK	2	
16-27	2206165	ASM-SMOOTH ROLLER, 4 IN	1	
16-28	2208006	BRG-19MM ID X 45.237 OD	2	
16-29	2208011-02	SEAL-OIL 1.375 X .750	2	
16-30	2208011-03	SEAL-OIL 2.000 X 1.250	2	
16-31	64123-206	BLT-HEX 5/8-11X4-1/2	2	
16-32	142108	CAP-SPINDLE	1	
16-33	64209-06	WSHR-CON SPRG 20.4MMID	12	
16-34	64163-03	WSHR-.256ID X .62OD	5	
16-35	2206178	S-DECK PIVOT	1	(INCLUDES ITEMS 34, 37 & 56)
16-36	2206202	S-YOKE PIVOT	1	(INCLUDES ITEMS 11 & 40)
16-37	A299301	ZERK-STRAIGHT M6-1.0	3	
16-38	2202307	BRACKET-BUMPER MNTG	1	
16-39	64229-06	LOCK NUT-NYLON 5/8-11	2	
16-40	85010N	ZERK, 1/4-28 STR SLF TH	4	
16-41	2208229	MOTOR-HYDRAULIC DECK	1	
	2208157-01	• SEAL KIT	A/R	
	2208157-02	• RELIEF VALVE	A/R	
16-42	64197-005	BLT-TDFM 3/8-16X1-1/4	6	

* Not Illustrated

**RANSOMES
AR 250
SERIES: VN**

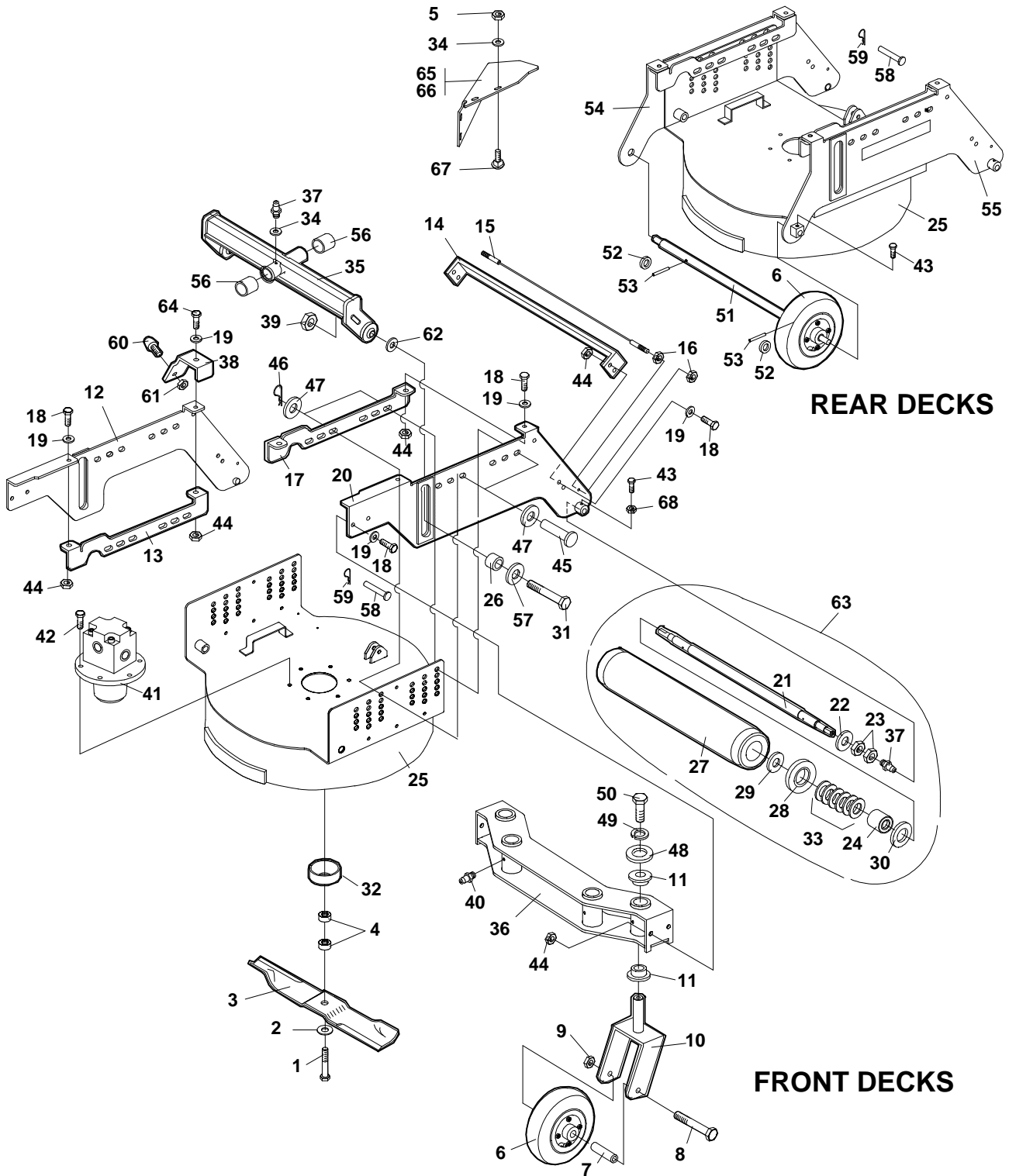

REAR DECKS

FRONT DECKS

DETAIL

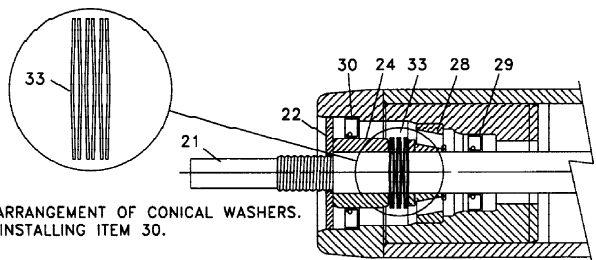

NOTE STACKING ARRANGEMENT OF CONICAL WASHERS.
INSTALL BEFORE INSTALLING ITEM 30.

SIDE DISCHARGE DECK

LIST OF PARTS

ITEM	RANSOMES PART NO	DESCRIPTION GB	QTY	REMARKS
16-43	64205-001	BLT METRIC M8-1.25 X 20	4	
16-44	64237-03	LOCKNUT-NYLON M10-1.5	12	
16-45	64188-04	PIN, CLEVIS 1/2X2-5/8	4	
16-46	64168-1	HAIRPIN COTTER	4	
16-47	64163-19	33/64X1-1/4X12GA WASHR	8	
16-48	64163-53	WASHER .391X1.50X9GA	2	
16-49	800488	LOCK WASHER M10	2	
16-50	64205-007	BLT METRIC M10-1.50X20	2	
16-51	2203086	SHAFT-WHEEL	1	
16-52	64163-71	WSHR-.762X1-1/4X.250	2	
16-53	64176-03	PIN, SPIRAL ROLL	2	
16-54	2206198.2	WLDMT-SIDE PLATE RH	1	
16-55	2206218.2	WLDMT-SIDE PLATE LH	1	
16-56	48048A	SLEEVE BEARING	2	
16-57	64163-76	WSHR-1-3/4 X 13/16 X 9/64	2	
16-58	64188-14	S PIN, CLEVIS 3/8X1.56	1	
16-59	64168-2	HAIRPIN COTTER	1	
16-60	523126	BUMPER-RUBBER	1	
16-61	64229-02	LOCK NUT-NYLON 5/16-18	1	
16-62	62464-1A	WASHER, THRUST 5/8X1.12 A/R		
16-63	2206195	S-SMOOTH ROLLER 22"	1	
16-64	64205-036	BLT-METRIC M10-1.50X35	1	
16-65	2202315.2	CHUTE	1	(USED ON 960025 & 960027)
16-66	2202366.2	CHUTE-SHORT	1	(USED ON 960023, 960024 & 960026)
16-67	64018-3	BLT-CRG 3/8-16X1	4	
16-68	64207-01	NUT-HEX,M8-1.25	4	

* Not Illustrated

RANSOMES
AR 250
SERIES: VN

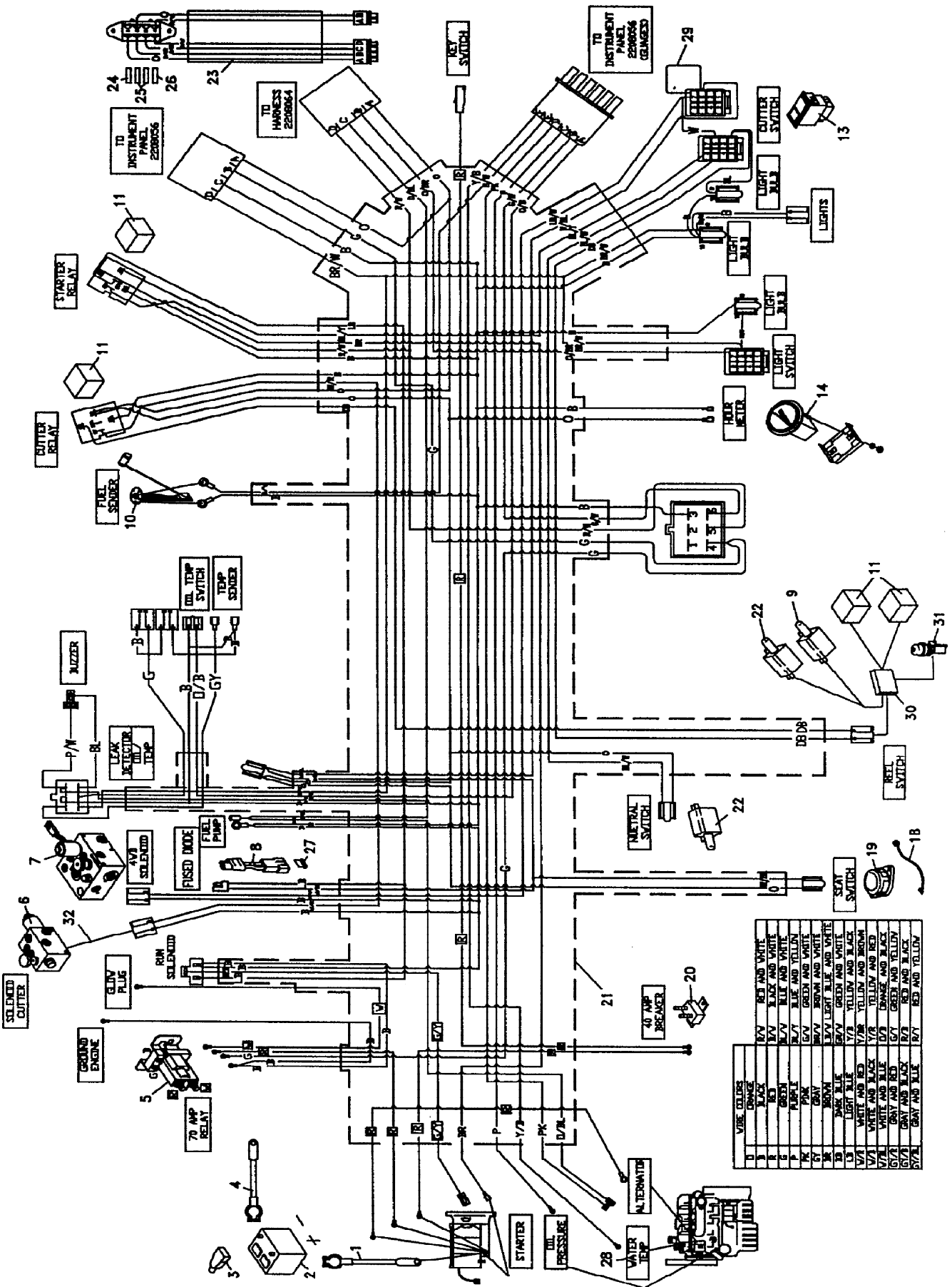

WIRE COLORS	
0	RED AND WHITE
1	ORANGE
2	BLACK
3	BLACK AND WHITE
4	RED
5	GREEN
6	FLUORESCENT BLUE AND WHITE
7	FLUORESCENT BLUE AND YELLOW
8	PINK
9	BROWN
10	GRAY
11	BROWN AND WHITE
12	GRAY LIGHT BLUE AND WHITE
13	GREEN AND WHITE
14	YELLOW AND BLACK
15	YELLOW AND BROWN
16	WHITE AND RED
17	WHITE AND BLACK
18	WHITE AND BLUE
19	ORANGE AND RED
20	GREEN AND BLACK
21	GRAY AND BLACK
22	RED AND BLACK
23	GRAY AND BLUE
24	RED AND YELLOW

ITEM	RANSOMES PART NO	DESCRIPTION 	QTY	REMARKS
15-1	148164	CABLE-BATTERY	1	FOR BATTERY LEAD
	A913498	CORUGATED CONDUIT	AR	
15-2	148074	BATTERY-BCI 26	1	
15-3	48037A	BOOT, BATTERY TERMINAL	1	
15-4	178083	CABLE-BATTERY NEGATIVE	1	
15-5	W38665	SOLENOID	1	
15-6	2198235	VALVE-BLADE DRIVE	1	
15-7	2208191	VALVE-4WD	1	
15-8	W178150	DIODE-6AMP WI5AMP FUSE	1	
15-9	W38382	SWITCH-N.O.	1	
15-10	2208037	MANIFOLD-INLET	1	
15-11	W128037	RELAY	4	
15-13	A905024	SWITCH-CUTTER	1	
15-14	A810966	HOUR METER ASSEMBLY	1	
15-18	158136	WIRE-SEAT SWITCH	1	
15-19	158135-01	SWITCH-SEAT, NO	1	
15-20	A824942	CIRCUIT BREAKER 40A	1	
15-21	A905598	HARNESS-WIRING MAIN	1	
15-22	38383	SWITCH-N.C.	2	
15-23	2208064	FUSE BLOCK AND HARNESS	1	
15-24	A823320	FUSE 30 AMP	1	
15-25	A823316	FUSE 10 AMP	1	
15-26	A823318	FUSE 20 AMP	1	
15-27	148082-05	FUSE-5 AMP	1	
15-28	W148270	SENDER-TEMP	1	
15-30	A905702	HARNESS-AR 250	1	
15-31	2208099	SWITCH-90043 CH-14	1	
15-32	2208190	WIRE-JUMPER DECK VALVE	1	
	A905715	HARNESS, L/A SWITCH	1	

* Not Illustrated

RANSOMES
AR 250
SERIES: VN

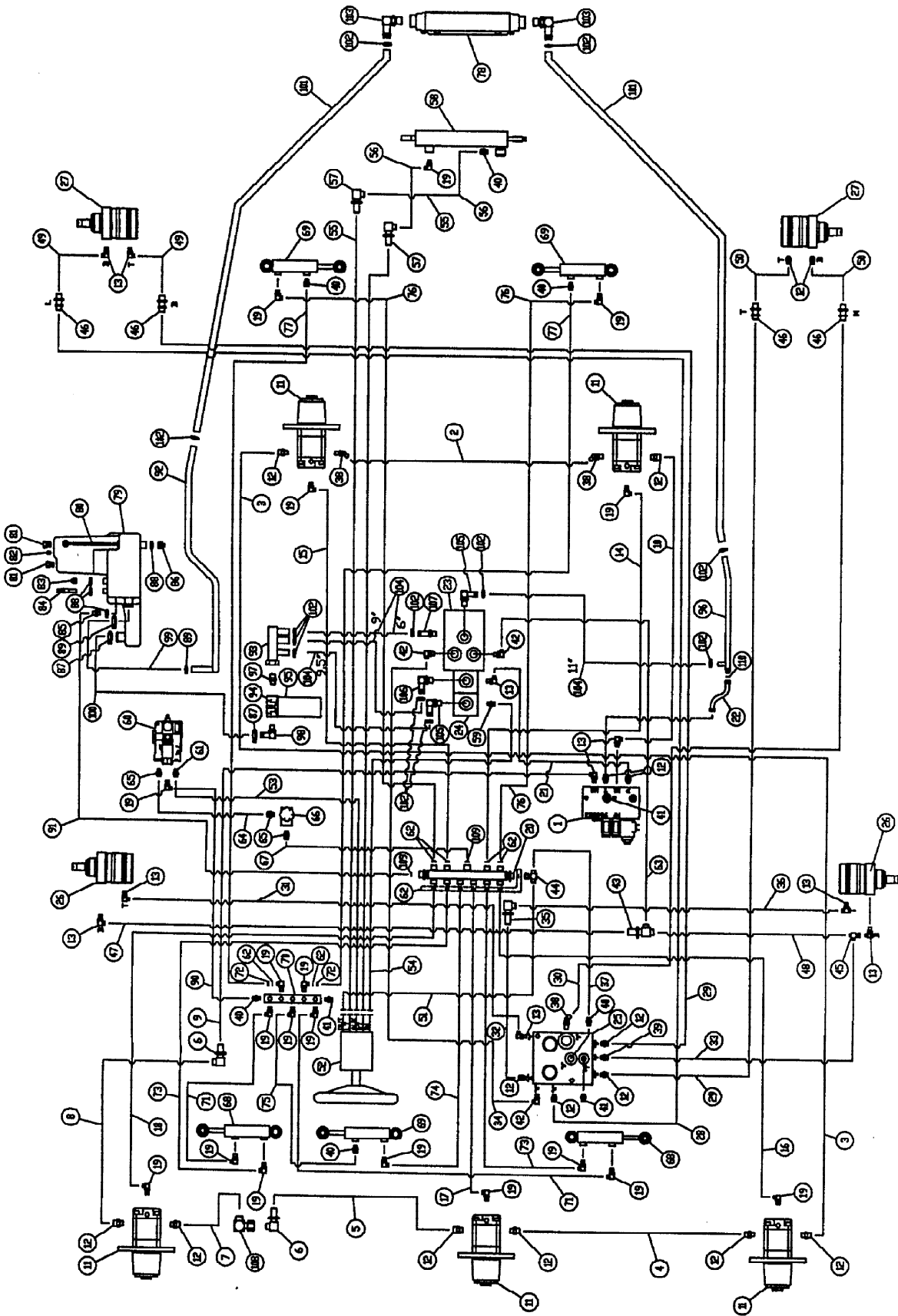

ITEM	RANSOMES PART NO	DESCRIPTION GB	QTY	REMARKS
16-1	2198235	VALVE-DECK (SEE PAGE 55 FOR SERVICE)	1	
16-2	2692267-03	HOSE-5/8 90 ORS/90 ORSX1 20.0	1	
16-3	2692267-04	HOSE-5/8 90 ORS/90 ORSX1 70.5	1	
16-4	2692267-05	HOSE-5/8 900RS190 ORSx82.0	1	
16-5	2692268-07	HOSE-5/8 ORS/90 ORSX48.0	1	
16-6	69055-04	FITTING ORS/ORS FORGED	2	
16-7	2692268-09	HOSE-518 ORS/90 ORSX43.50	1	
16-8	2692268-04	HOSE-518 ORS/90 ORSX54.25	1	
16-9	2692265-08	HOSE-518 ORS/45 OR X59.50	1	
16-10	2692268-10	HOSE-518 ORSI90 ORS X 95.0	1	
16-11	2208157	MOTOR HYDRAULIC DECK	5	(USE SEAL KIT 2208157-01) (USE SEAL KIT 2208157-02)
16-12	158006-07	FITTING-ORBIORS	18	
16-13	158007-05	FITTING-90 ORS/ORB	10	
16-14	2692253-15	HOSE-318 ORS/90 OR X100.s	1	
16-15	2692253-16	HOSE-3/8 ORS/90 ORX107.00	1	
16-16	2692253-21	HOSE-3/8 ORS/90 ORSX67.50	1	
16-17	2692253-18	HOSE-3/8 ORS/90 ORSX93.00	1	
16-18	2692253-20	HOSE-3/8 ORS/90 ORS x 85.50	1	
16-19	158007-01	FITTING-90 ORS/ORB	19	
16-20	2208028	MANIFOLD-RETURN	1	
16-21	2692268-08	HOSE-5/8 ORS/90 ORS x 18.50	1	
16-22	2208189	TUBE-OIL COOLER/VALVE	1	
16-23	2208192	PUMP-M35	1	(PAGES 56 & 57 FOR SERVICE)
6-24	2208182	PUMP-2 SECTION	1	(SEAL KIT 2208182-01)
16-25	2208191	VALVE-4WD AR 250	1	(PAGE 52 FOR SERVICE)
16-26	A800698	MOTOR-WHL ME29O2O8AABT	2	
16-27	148141-07	MOTOR-WHL ME21O2O8MBT	2	
16-28	2692268-02	HOSE-5/8 ORS/90 ORS x 51.25	1	
16-29	2692268-03	HOSE-5/8 ORS/90 ORS x 45.25	2	
16-30	2692260-07	HOSE-5/8 ORS/ORS x 42.50	1	
16-31	2692265-07	HOSE-5/8 ORS/45 ORS x 35.75	1	
16-32	2692268-11	HOSE-518 ORS/90 ORS X 14.0	1	
16-33	2692256-04	HOSE-112 90 ORS/90 ORSX31 .0	1	
16-34	2692273-01	HOSE-3/4 ORS/45 ORS x 14.50	1	
16-35	69055-03	FITTING-90 ORS/ORS	1	
16-36	2692260-06	HOSE-518 ORSIORS x 30.50	1	
16-37	2692253-13	HOSE-3/8 ORS/90 ORS 15.25	1	
16-38	158059-06	FITTING-45 ORSIORB ADJ	3	
16-39	158006-04	FITTING-ORS/ORB	1	
16-40	158006-01	FITTING-ORS/ORB	6	
16-41	178079	TEST FINING	3	
16-42	158007-07	FITTING-90 ORS/ORB	3	
16-43	69056-01	FITTING-ORS RUN TEE	1	
16-44	69057-01	FIUING-ORS BRANCH TEE	1	
16-45	158010-02	FTG-ORS RUN TEE	1	

* Not Illustrated

RANSOMES
AR 250
SERIES: VN

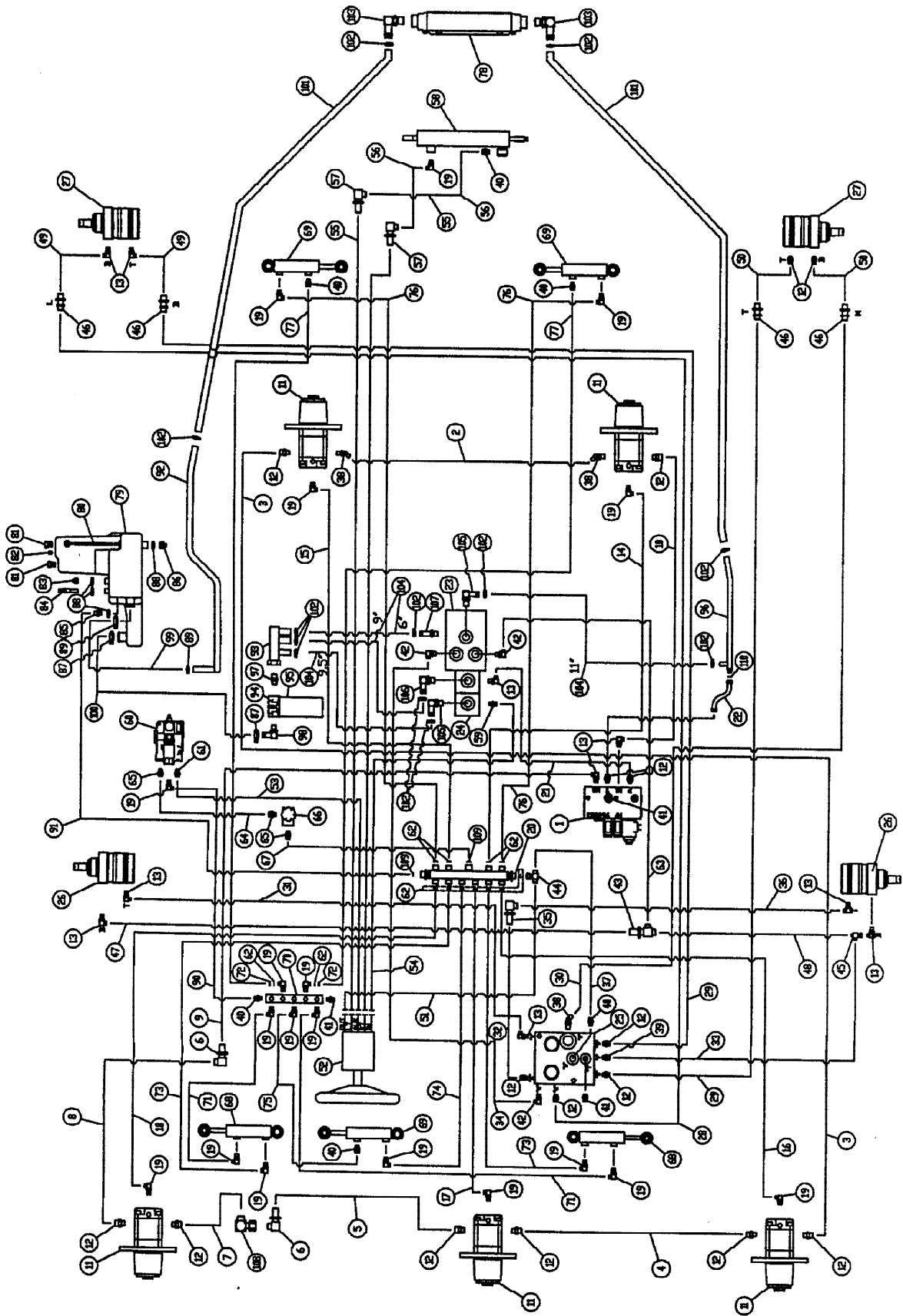

HYDRAULIC SYSTEM

LIST OF PARTS

ITEM	RANSOMES PART NO	DESCRIPTION 	QTY	REMARKS
16-46	158067-02	FITTING-BLKHD ORS/ORS	4	
16-47	2692260-02	HOSE-5/8 ORS/ORS x 29a25	1	
16-48	2692260-05	HOSE-518 ORS/ORS x 19.25	1	
16-49	2692265-09	HOSE-5/8 ORS145 ORS X 29.0	2	
16-50	2692268-06	HOSE-518 ORSI90 ORS x 28.00	2	
16-51	2692252-09	HOSE-3/8 ORS/ORS x 41.75	1	
16-52	2208142	STEER GEAR	1	
16-53	2692253-10	HOSE-3/8 ORSI90 ORS x 67.50	3	
16-53	2692253-10	HOSE-3/8 ORS/90 ORS x 67.50	3	
16-54	2692253-11	HOSE-3/8 ORS/90 ORS x 58~50	1	
16-55	2692253-19	HOSE-3/8 ORS/90 ORSX115.75	2	
16-56	2692255-03	HOSE-318 ORS/45 ORS x 21.75	2	
16-57	69055-01	FITTING-90 ORS/ORS	2	
16-58	198040	CYLINDER-STEERING	1	
16-59	158006-03	FITTING-ORSIORB	1	
16-60	2208144	VALVE-LIFT	1	
16-61	158006-13	FTG-6ORS/8ORB	1	
16-62	158061-01	O-RING -06	14	
16-63	2692262-01	HOSE-314 ORS/ORSX21 .0	1	
16-64	2208068	TUBE-LIFT VALVE	1	
16-65	158006-05	FITTING ORS/ORB	3	
16-66	2208046	VALVE BLOCK-BACK PRES	1	
16-67	2692256-01	HOSE-1/2 90 ORS/90 ORSX24.0	1	
16-68	2208151	CYLINDER-REEL, LONG	2	
16-69	2208152	CYLINDER-REEL, SHORT	3	
16-70	2208051	MANIFOLD-LIFT	1	
16-71	2692252-01	HOSE-3/8 ORS/ORS x 19.75	2	
16-72	69068-01	ORIFICE DISK 06, .052	2	
16-73	2692255-10	HOSE-3/8 ORS/45 ORS X 11.5	2	
16-74	2692255-01	HOSE-3/8 ORS/45 ORS x 15.00	1	
16-75	2692253-01	HOSE-318 ORS/90 ORS x 25.25	1	
16-76	2692255-02	HOSE-3180RS/450RSX72.25	2	
16-77	2692253-02	HOSE-3/8 ORS/90 ORS x 77.25	2	
16-78	2208026	COOLER-OIL	1	
16-79	2208031	RESERVOIR-HYDRAULIC	1	
16-80	158122-02	TUBING-SIGHT GLASS	1	
16-81	2690017-01	FTG-ORB PLUG 14	2	
16-82	148027	BREATHERVENT	1	
16-83	69051-01	PIPEPLUG-3/8	1	
16-84	2208083	SWITCH, TEMP-MODEL TT	1	
16-85	158065-03	FITTING-ORS/NPTF	1	
16-86	108029	PLUG, MAGNETIC	1	
16-87	48383	CLAMP-HOSE 2-1/2 DIA	2	
16-88	108094-06	HOSE CLAMP #10	4	
16-89	48396	CLAMP-HOSE 2 DIA	2	
16-90	2692254-01	HOSE-318 900R5/450RSx12.38	1	
16-91	2692258-02	HOSE-1/2 ORSIORS X 7.25	1	

* Not Illustrated

RANSOMES
AR 250
SERIES: VN

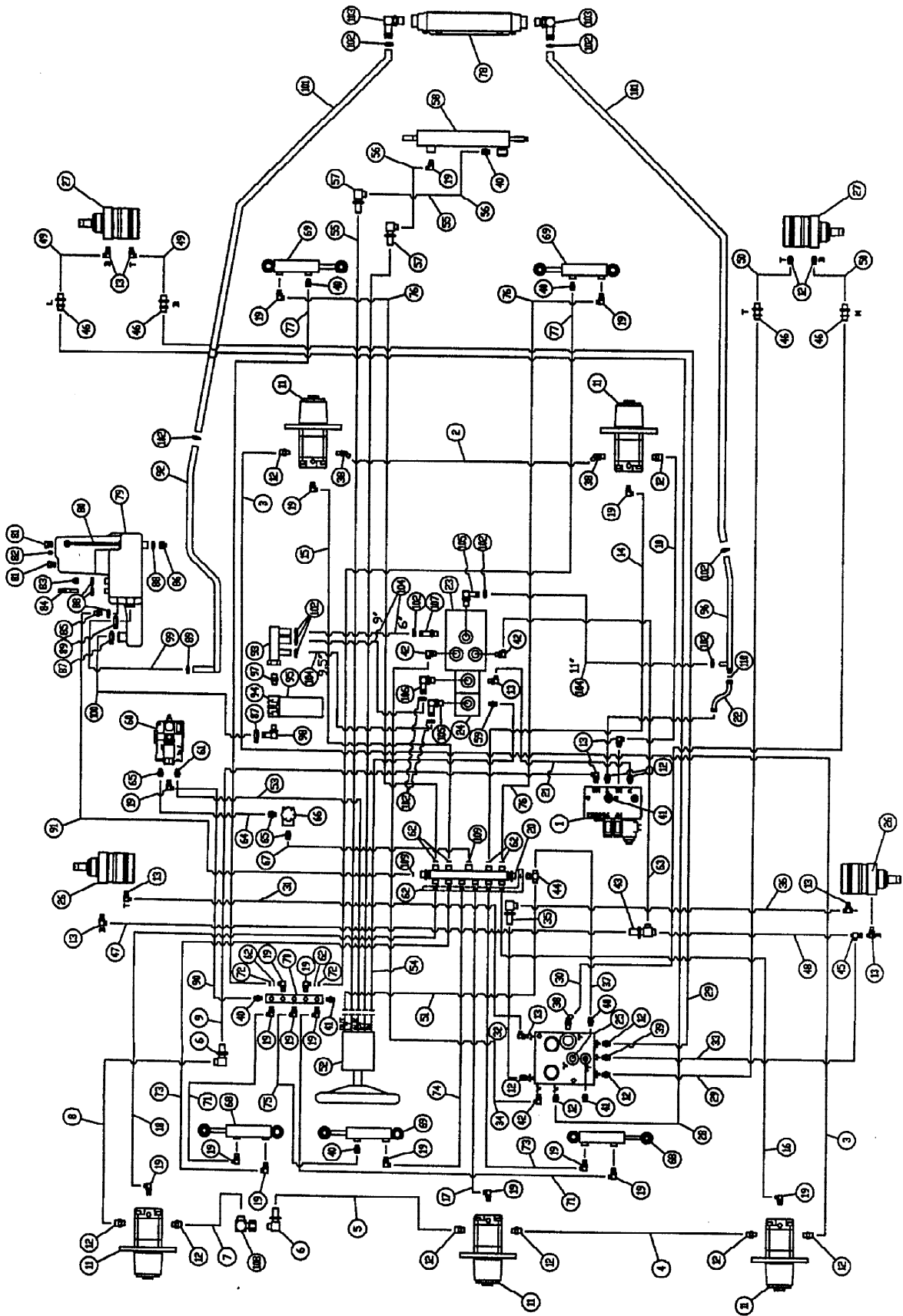

ITEM	RANSOMES PART NO	DESCRIPTION GB	QTY	REMARKS
16-92	2203053	TUBE-OIL RESERVOIR	1	
16-93	2208162	MANIFOLD-INLET AR 250	1	
16-94	2208038	FILTER HEAD-SPIN ON	1	
16-95	W178025	FILTER-SPIN ON	1	
16-96	2208130	TUBE-OIL COOLER LH	1	
16-97	158006-12	FITTING-ORBIORS	1	
16-98	158058-08	FITTING-90 BARB, ADJ	1	
16-99	69059-02	S HOSE, HYD, 1.251DX6 LG	1	
16-100	2692233-01	S-HOSE-1 .50 X 2.12	1	
16-101	2692232-02	HOSE-1.25 X 21 WIRE REINF	2	
16-102	108094-01	HOSE CLAMP .75 TO 1.75	12	
16-103	158058-09	FITTING-90 BARB, ADJ	2	
16-104	108092-01	S HOSE, 12.0	4	
16-105	158058-02	FITTING-90 BARB, ADJ	2	
16-106	158058-03	FITTING-90 BARB, ADJ	1	
16-107	69060-03	FITTING-BARB, ADJ	1	
16-108	158066-04	FTG-ORS/ORB	1	
16-109	158061-02	O-RING	2	
16-110	158061-08	O-RING	1	
	A907931	TUBE CLAMP	3	

* Not Illustrated

RANSOMES
AR 250
SERIES: VN

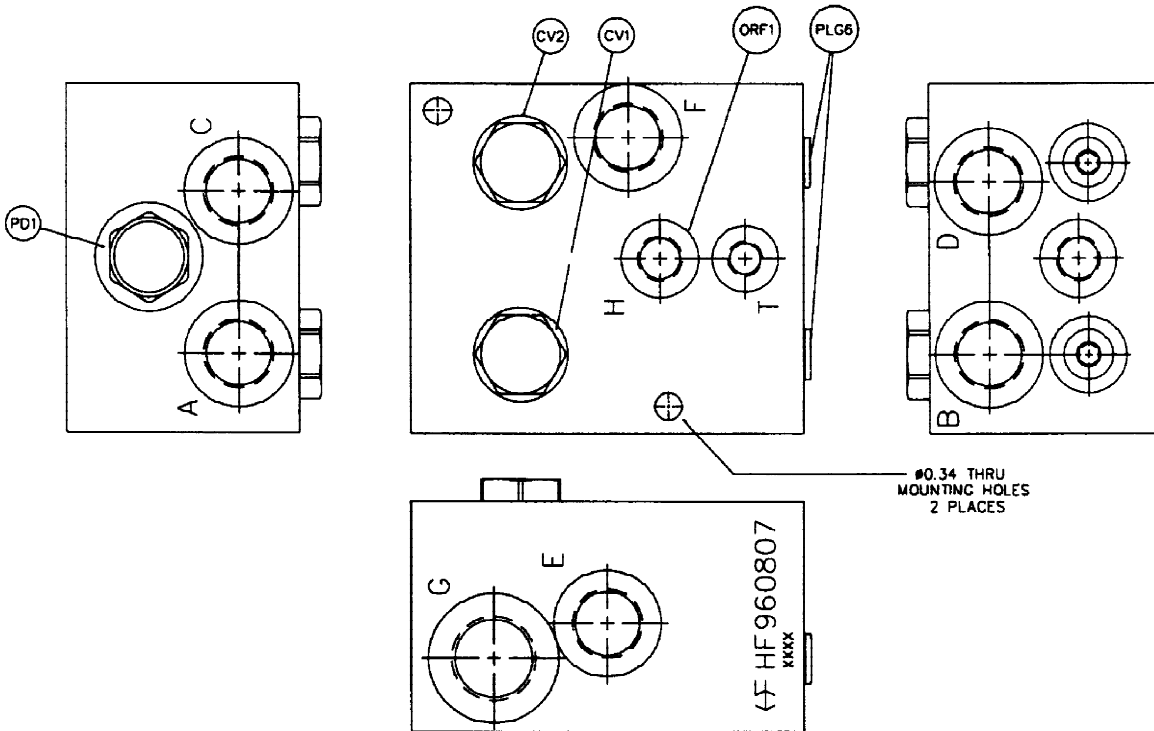

Ø.34 THRU
 MOUNTING HOLES
 2 PLACES

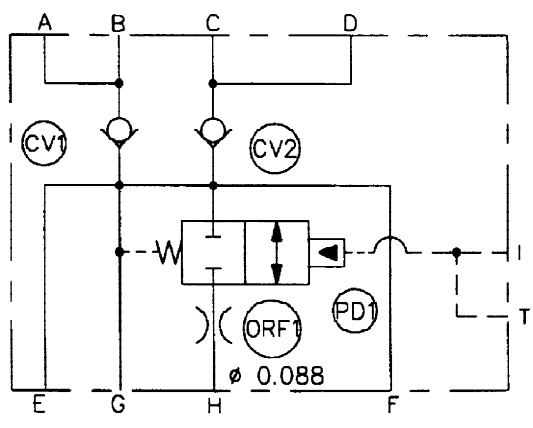

ITEM	RANSOMES PART NO	DESCRIPTION 	QTY	REMARKS
CV1	2208191	VALVE 4 WHEEL DRIVE	1	
	178102-78	• VALVE	1	
	178102-01	•• SEAL KIT	1	
CV2	178102-78	• VALVE	1	
	178102-01	•• SEAL KIT	1	
PD1	178102-53	• VALVE	1	
	178102-54	•• SEAL KIT	1	
PLG6	178102-61	• PLUG	2	
	178102-63	•• SEAL	1	
DRF1	178102-51	• ORIFICE PLUG	1	

RANSOMES
AR 250
SERIES: VN

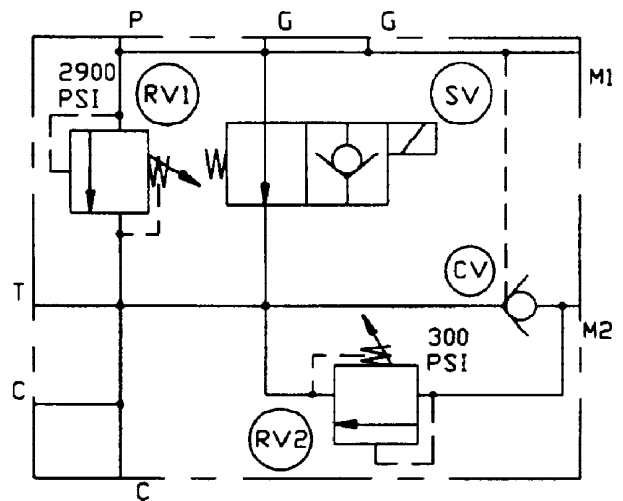
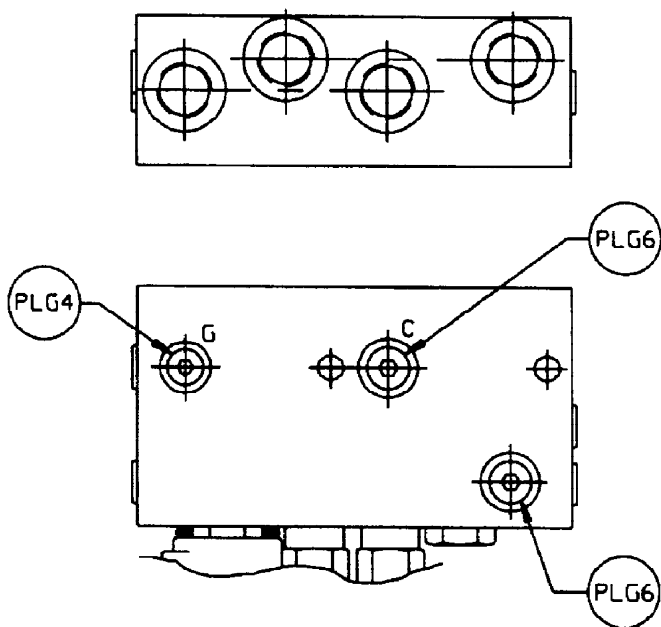
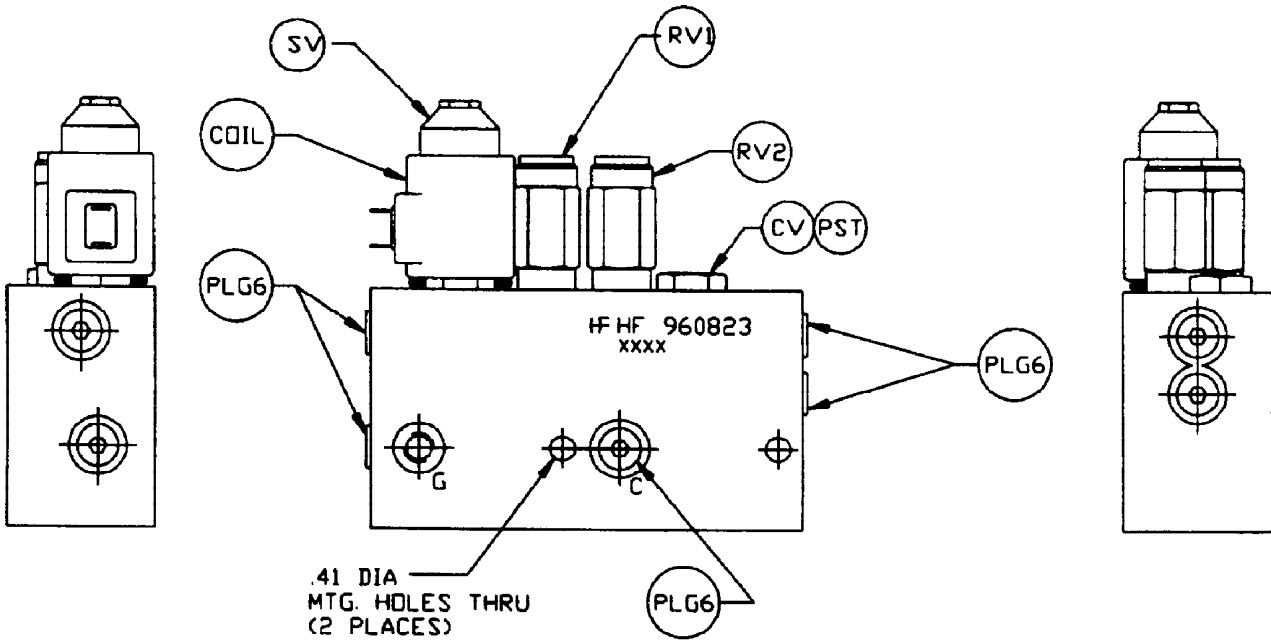

ITEM	RANSOMES PART NO	DESCRIPTION GB	QTY	REMARKS
	2198235	DECK VALVE	1	
RV1	178102-12	• RELIEF VALVE	1	
	178102-02	•• SEAL KIT	1	
RV2	178102-13	• RELIEF VALVE	1	
	178102-01	•• SEAL KIT	1	
CV	178102-31	• CHECK VALVE	1	
	178102-01	•• SEAL KIT	1	
PST	178102-14	• PILOT PISTON	1	
SV	178102-16	• SOLENOID VALVE	1	
	178102-01	•• SEAL KIT	1	
COIL	178102-17	• COIL	1	
PLG6	178102-18	• PLUG	7	
	178102-10	•• SEAL	1	
PLG4	178102-19	• PLUG	1	
	178102-09	•• SEAL	1	

* Not Illustrated

RANSOMES
AR 250
SERIES: VN

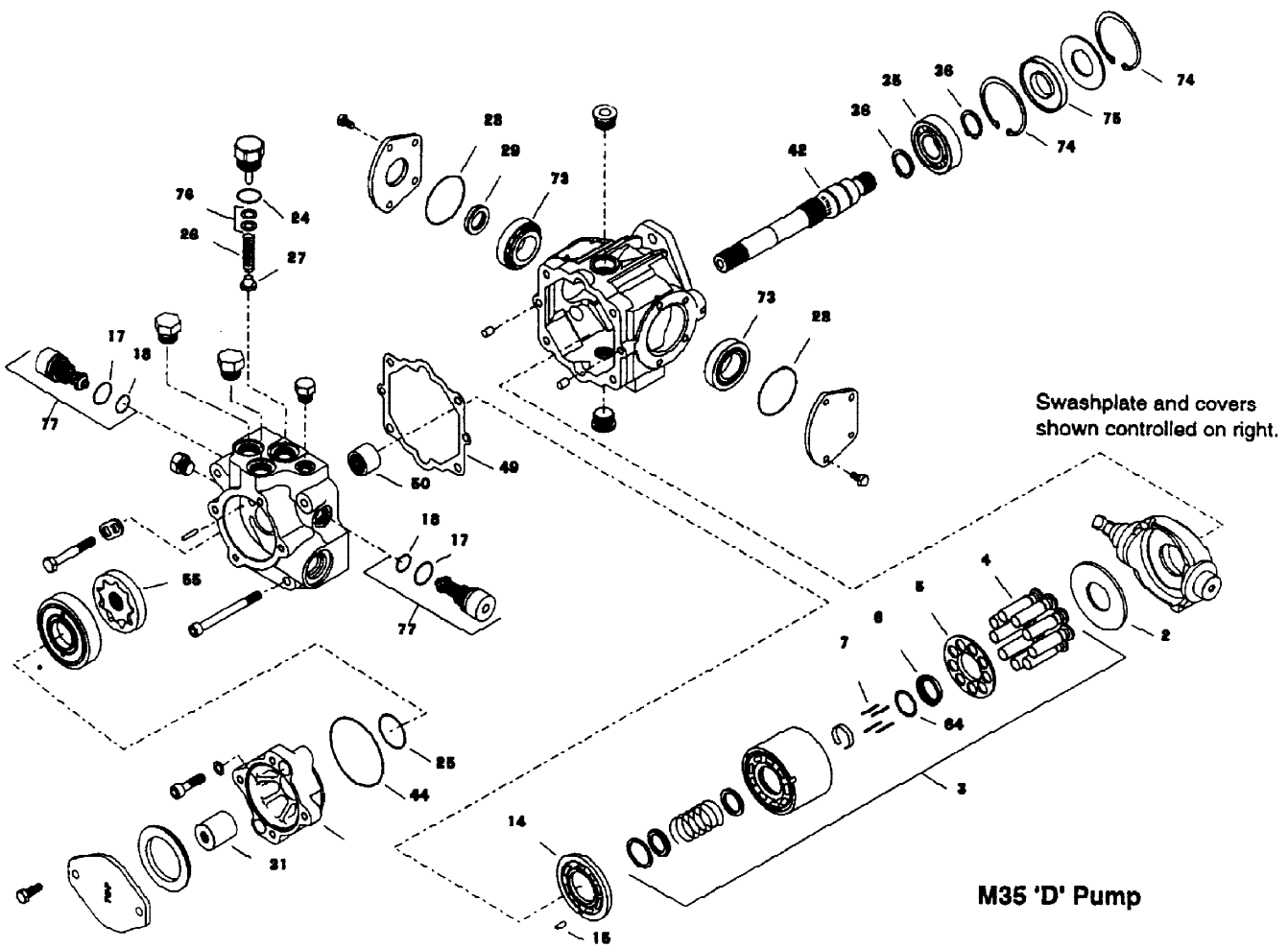

TRANSMISSION PUMP (SAUER SUNDSTRAND)

LIST OF PARTS

ITEM	RANSOMES PART NO	DESCRIPTION 	QTY	REMARKS
21-2	178037-02	THRUST PLATE	1	
21-3	178037-03	CYLINDER BLOCK KIT	1	
21-4	178037-04	PISTON ASSEMBLY	1	
21-5	178037-05	SLIPPER RETAINER	1	
21-6	178037-06	SLIPPER RTAR GUIDE	1	
21-7	178037-07	SLIPPER HLD DWN PIN	1	
21-14	178037-14	VALVE PLATE, RH	1	
21-15	178037-15	SPRING PIN	1	
21-17	178037-17	O-RING	2	
21-18	178037-18	O-RING	2	
21-24	178037-24	O-RING	1	
21-25	178037-25	O-RING	1	
21-26	178037-26	SPRING	1	
21-27	178037-27	CHARGE RLF POPPET	1	
21-28	178037-28	O-RING	2	
21-29	178037-29	LIP SEAL	1	
21-31	178037-31	COUPLING	1	
21-35	178037-35	BALL BEARING	1	
21-36	178037-36	RETAINING RING	2	
21-42	178037-42	FRONT SHAFT, 15 UH	1	
2149	178037-49	END CAP GASKET	1	
21-50	178037-50	NEEDLE BEARING	1	
21-55	178037-55	GEROTOR ASSEMBLY	1	
21-64	178037-64	WASHER, SPECIAL	1	
21-73	178037-73	BEARING	2	
21-74	178037-74	RETAININGRING	2	
21-75	178037-75	LIP SEAL	1	
21-76	178037-76	CHARGE RLF SHIM KIT	1	
21-77	178037-77	SCR VALVE ASSY	2	

* Not Illustrated

AR250 ENVIRODECK

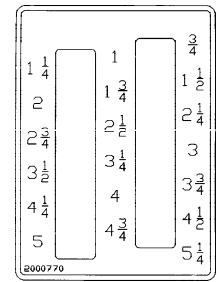
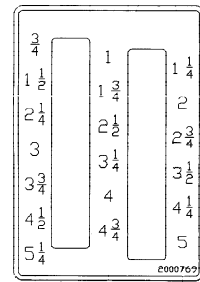
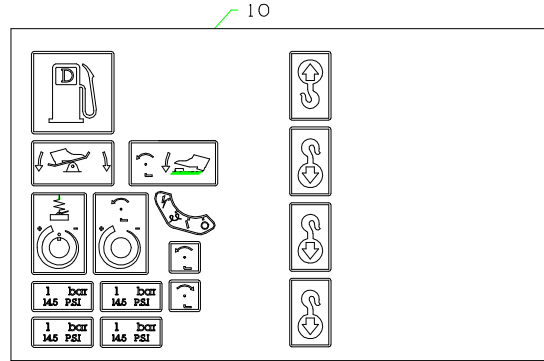
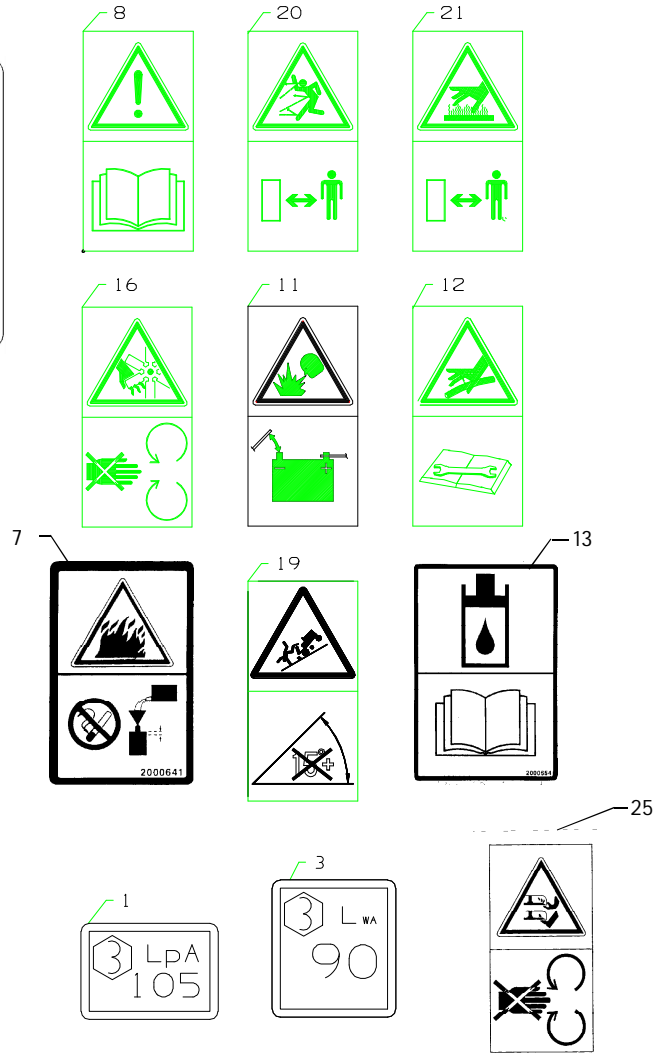
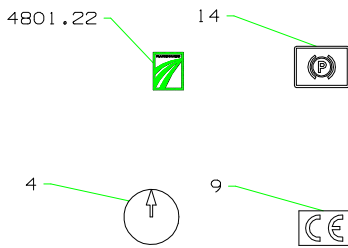
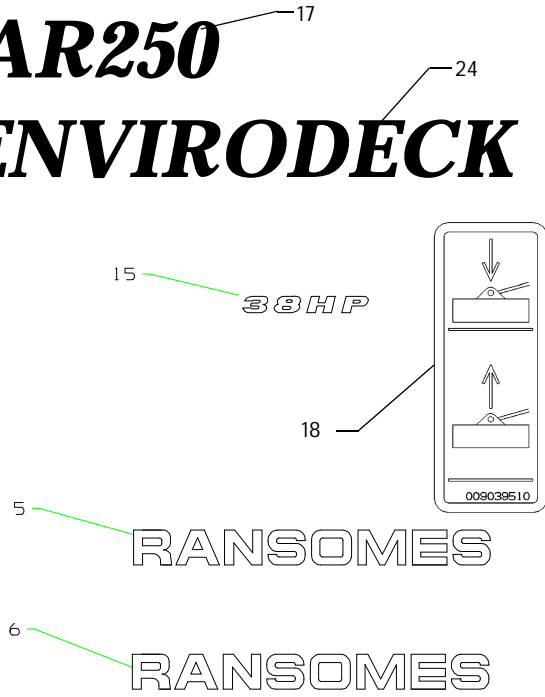

ITEM	RANSOMES PART NO	DESCRIPTION 	QTY	REMARKS
1	A903477	DECAL - NOISE 105	1	
2	W00465	DECAL - FAST/SLOW	1	
3	A903474	DECAL - NOISE 90	1	
4	2000616	LABEL,ADJUST KNOBS	1	
5	2000621	LABEL - 4 WD DIECUT	2	
6	2000628	LABEL, 9" RANSOMES DIECUT	1	
7	2000641	LABEL - EXPLOSION FUEL EEC	1	
8	A903491	DECAL - INSTRUCTION	1	
9	A903929	C E DECAL	1	
10	A903342	SET OF DECAL:	1	
11	A911410	DECAL - BATTERY	1	
12	A903493	DECAL - HYD PRESS LEAK	1	
13	2000654	LABEL - HYDRAULIC FILL	1	
14	A903970	DECAL - PARKING BRAKE	1	
15	A903936	LABEL - 38HP F/WAY 300	2	
16	A903488	DECAL - FAN	1	
17	2000750	DECAL - AR 250	3	
18	A903951	LABEL - REEL LIFT	1	
19	A911416	DECAL - SLOPE 15 DEG	1	
20	A903489	DECAL - BYSTANDER	1	
21	A903492	DECAL - HOT	1	
22	2000769	DECAL - HEIGHT OF CUT LH	AR	
23	2000770	DECAL - HEIGHT OF CUT RH	AR	
24	2000749	DECAL - ENVIRODECK	AR	
25	A903496	DECAL - ROTATING BLADE	AR	

* Not Illustrated

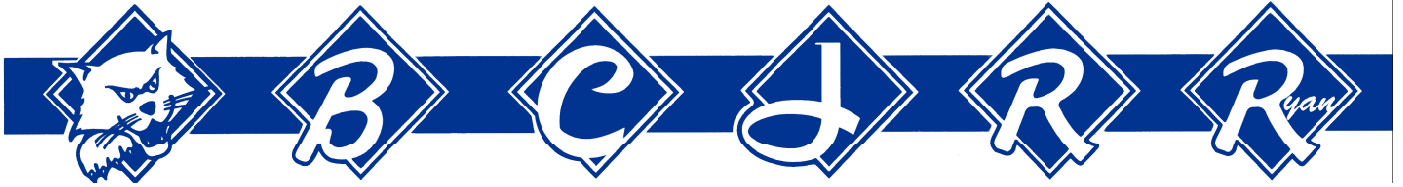

World Class Quality, Performance and Support

Equipment from Textron Turf Care and Specialty Products is built to exacting standards ensured by ISO 9001 registration at all our manufacturing locations.

A worldwide dealer network and factory-trained technicians backed by Textron Parts Xpress provide reliable, high-quality product support.



TEXTRON
TURF CARE AND SPECIALTY PRODUCTS

BOB-CAT BUNTON CUSHMAN JACOBSEN RANSOMES RYAN

Ransomes Jacobsen Limited 1999
Ransomes Way, Ipswich, England, IP3 9QG
English Company Registration No. 1070731
www.textronturf.com