



Setup, Parts and Maintenance Manual

RANSOMES[®] *EC Cutter Decks*

Cutting Unit Models:

933506 Cutter Deck 36" Rear Discharge EC

933407A Cutter Deck 36" Side Discharge EC

(Safety & Operation Manual: 4122571, 4122451))



WARNING: If incorrectly used this machine can cause severe injury. Those who use and maintain this machine should be trained in its proper use, warned of its dangers and should read the entire manual before attempting to set up, operate, adjust or service the machine.



IMPORTANT MESSAGE

Thank you for purchasing this Ransomes product. You have purchased a world class mowing product, one of the best designed and built anywhere.

This machine comes with an Operation and Safety Manual and a separate Setup, Parts and Maintenance Manual. The useful life and good service you receive from this machine depends to a large extent on how well you read and understand these manuals. Treat your machine properly, lubricate and adjust it as instructed, and it will give you many years of reliable service.

Your safe use of this Ransomes product is one of our prime design objectives. Many safety features are built in, but we also rely on your good sense and care to achieve accident-free operation. For best protection, study the manuals thoroughly. Learn the proper operation of all controls. Observe all safety precautions. Follow all instructions and warnings completely. Do not remove or defeat any safety features. Make sure those who operate this machine are as well informed and careful in its use as you are.

See a Ransomes dealer for any service or parts needed. Ransomes service ensures that you continue to receive the best results possible from Ransomes' products. You can trust Ransomes replacement parts because they are manufactured with the same high precision and quality as the original parts.

Ransomes designs and builds its equipment to serve many years in a safe and productive manner. For longest life, use this machine only as directed in the manuals, keep it in good repair and follow safety warnings and instructions. You'll always be glad you did.

**Textron Golf, Turf & Specialty Products
Central Avenue, Ransomes Europark
Ipswich, England, IP3 9QG**

TABLE OF CONTENTS	FIGURES	PAGE
SAFETY		2
ASSEMBLY/SET-UP INSTRUCTIONS		3, 4
PARTS SECTION		5
36" EC SIDE DISCHARGE DECK	FIGURE 1	6, 7
36" EC REAR DISCHARGE DECK	FIGURE 2	8, 9
CASTER ASSY-FIXED DECKS	FIGURE 3	10, 11
SPINDLE ASSEMBLY	FIGURE 4	12, 13
DECALS	FIGURE 5	14, 15

NOTICE !!!

Unauthorized modifications may present **extreme** safety hazards to operators and bystanders and could also result in product damage.

Textron Golf, Turf & Specialty Products strongly warns against, rejects and disclaims any modifications, add-on accessories or product alterations that are not designed, developed, tested and approved by Textron Golf, Turf & Specialty Products Engineering Department. Any Textron Golf, Turf & Specialty Products product that is altered, modified or changed in any manner not specifically authorized after original manufacture—including the addition of “after-market” accessories or component parts not specifically approved by Textron Golf, Turf & Specialty Products—will result in the Textron Golf, Turf & Specialty Products Warranty being voided.

Any and all liability for personal injury and/or property damage caused by any unauthorized modifications, add-on accessories or products not approved by Textron Golf, Turf & Specialty Products will be considered the responsibility of the individual(s) or company designing and/or making such changes. Textron Golf, Turf & Specialty Products will vigorously pursue full indemnification and costs from any party responsible for such unauthorized post-manufacture modifications and/or accessories should personal injury and/or property damage result.



This symbol means:
ATTENTION!
BECOME ALERT!

Your safety and the safety of others is involved.

Signal word definitions:

The signal words below are used to identify levels of hazard seriousness. These words appear in this manual and on the safety labels attached to Textron Golf, Turf & Specialty Products machines. For your safety and the safety of others, read and follow the information given with these signal words and/or the symbol shown above.

DANGER

DANGER indicates an imminently hazardous situation which, if not avoided, **WILL** result in death or serious injury.

WARNING

WARNING indicates a potentially hazardous situation which, if not avoided, **COULD** result in death or serious injury.

CAUTION

CAUTION indicates a potentially hazardous situation which, if not avoided, **MAY** result in minor or moderate injury. It may also be used to alert against unsafe practices or property damage.

CAUTION

CAUTION used without the safety alert symbol indicates a potentially hazardous situation which, if not avoided, **MAY** result in property damage



SERIAL TAG

MODEL NUMBER: This number appears on sales literature, technical manuals and price lists.

SERIAL NUMBER: This number appears only on your mower. It contains the model number followed consecutively by the serial number. Use this number when ordering parts or seeking warranty information.

FIXED CUTTERDECK ATTACHMENT

1. Remove the cutterdeck from the crate.
2. Unbolt the caster wheels and the shipping brackets from the crate.
3. Remove the shipping bracket from the caster wheel by loosening the caster bolt and sliding the shipping bracket off and retighten caster bolt.
4. Remove quick pin and remove the appropriate number of spacers for the desired height of cut. See height of cut chart below.

NOTE: Height of cut chart is also located on bottom of belt cover or in the Operation & Safety Manual.

5. Repeat for other caster wheel assembly.

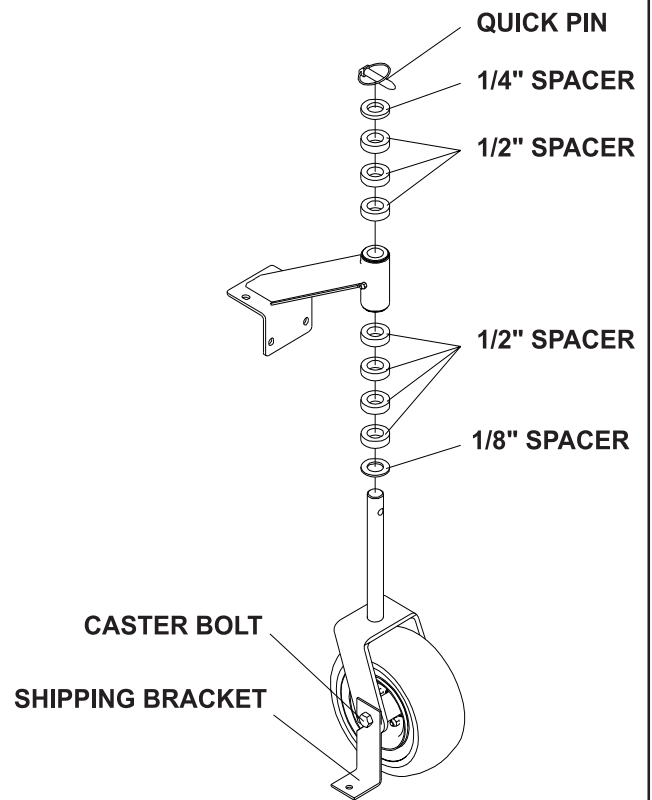

CUTTING HEIGHT		A (1/8")	B (1/4")	C (1/2")	DECK PIN POSITION	NUMBER OF SPACERS BETWEEN SPINDLE AND BLADE (1/4" THICK)
1.375	35	1	0	1	5	2
1.625	41	1	0	1	5	1
1.875	48	1	0	1	5	0
2.125	54	1	1	2	4	2
2.375	60	1	1	2	4	1
2.625	67	1	1	2	4	0
2.875	73	1	0	4	3	2
3.125	79	1	0	4	3	1
3.375	86	1	0	4	3	0
3.625	92	1	1	5	2	2
3.875	98	1	1	5	2	1
4.125	105	1	1	5	2	0
4.375	111	1	0	7	1	2
4.625	118	1	0	7	1	1

ASSEMBLY/SET-UP INSTRUCTIONS

EC Midsize Decks

- Remove belt cover and set aside.
- Block the rear of the cutterdeck with the appropriate height block for the desired height of cut **B**. See Support Block Chart below.

CUTTING HEIGHT	HOLE POSITION ON ENGINE DECK*	BLOCK HEIGHT AT REAR OF DECK (B)
1.375" - 1.625"	5	1.25"
1.875" - 2.375"	4	2.00"
2.625" - 3.125"	3	2.75"
3.375" - 3.875"	2	3.50"
4.125" - 4.625"	1	4.25"

* Position 1 is the highest hole on the engine deck.

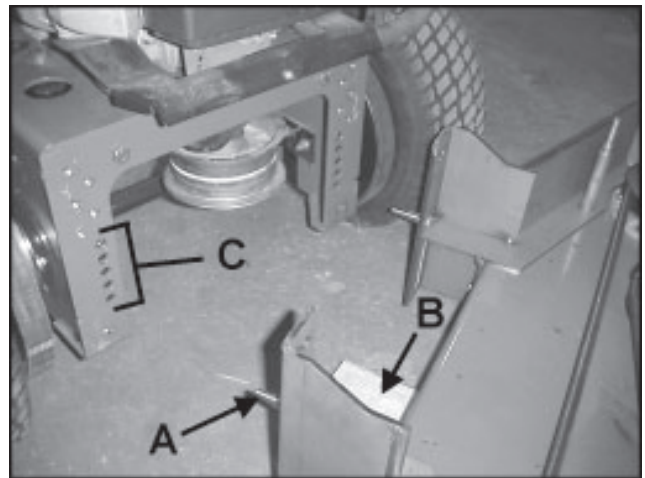

- Position the power unit behind the cutterdeck.
- Move the power unit towards the cutterdeck until the guide pins **A** engage the appropriate hole **C** on the power unit for the desired height of cut. Fasten with (4) M12-1.75 X 30 bolts at **D**.
- Loop the PTO belt **E** around the electric clutch pulley. Using a 3/8" ratchet wrench or 3/8" breaker bar rotate the PTO belt idler while looping the PTO belt around the cutterdeck pulley.

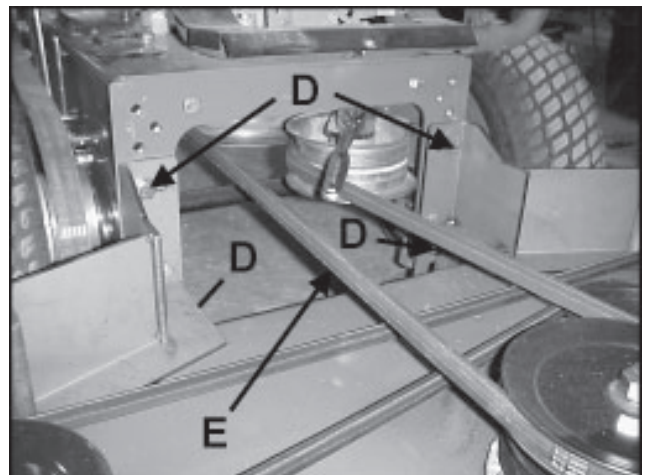

- Reinstall belt cover and fasten in place with knobs **F**.
- Remove support block from the rear of cutterdeck.
- Remove support from the rear of the power unit.



PARTS SECTION

36" EC SIDE DISCHARGE DECK

EC
Midsize
Decks

FIGURE 1

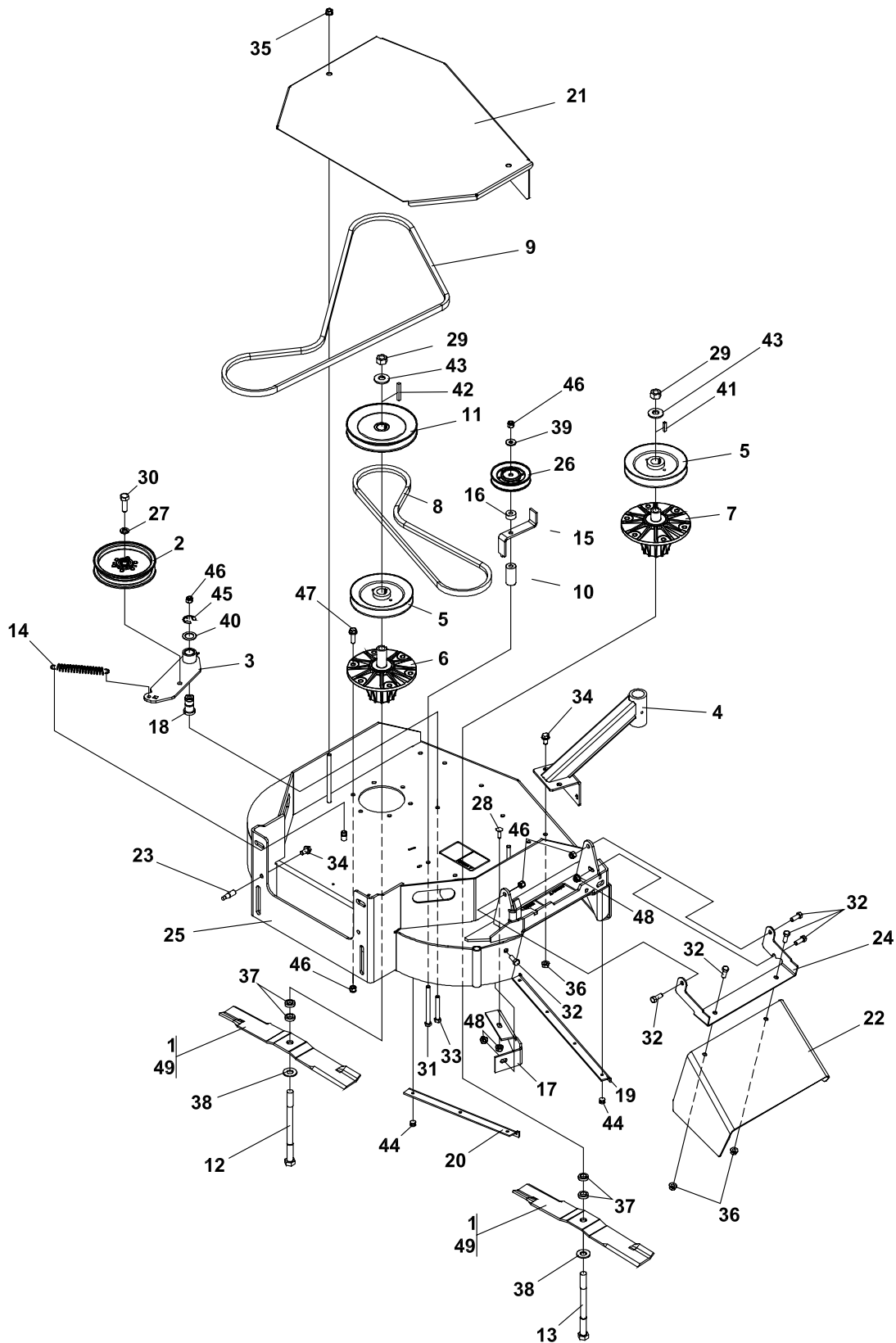

EC Midsize Decks

36" EC SIDE DISCHARGE DECK

4122042-01

FIGURE 1

ITEM	PART NO.	DESCRIPTION	QTY	ITEM	PART NO.	DESCRIPTION	QTY
1-1	112243-02	BLADE 18.00 OFFST	2				
1-2	128169	PULLEY, IDLER 5.50	1				
1-3	2186138.7	WLDMT-DECK IDLER	1				
1-4	2306029	S CASTER SUPPORT	2				
1-5	2308140	PULLEY-ENGINE	2				
1-6	2721097	S-ASSY SPNDL 6 LNG	1				
1-7	2721323	S-ASSY SPNDL 6 SHRT	1				
1-8	2721477	BELT-HB 56.75	1				
1-9	2721478	BELT-HB 85.25	1				
1-10	2721485	SPACER-IDLER	1				
1-11	2722161	PULLEY-6.75 EOD	1				
1-12	33049-02	BOLT-BLADE	1				
1-13	33049-05	BOLT-BLADE	1				
1-14	38219	SPRING-TENSION	1				
1-15	4115420.7	GUIDE-BELT	1				
1-16	4115424	SPCR-10.31 X 25.4 X 12.0	1				
1-17	4115864.7	BAFFLE-DISCHARGE	1				
1-18	4116661	PIN-PIVOT	1				
1-19	4119062.2	BRKT-EC FRONT DECK, RH	1				
1-20	4119063.2	BRKT-EC FRONT DECK, LH	1				
1-21	4119064.2	COVER-BELT, 36 FIXED	1				
1-22	4119065.2	CHUTE-DECK, 32-54 SD	1				
1-23	4119573	PIN-GUIDE	2				
1-24	4127148.2	BRKT-CHUTE SUPPORT EC	1				
1-25	4127209	S-36 DECK SD W/LABS EC	1				
1-26	48393	PULLEY-VIDLER	1				
1-27	64006-05	LOCKWSHR-HELICAL 1/2	1				
1-28	64018-3	BOLT-3/8-16X1 CARRIAGE	1				
1-29	64025-16	NUT-HEX 5/8-18	2				
1-30	64123-05	BLT-HEX 1/2-20X1-1/2	1				
1-31	64123-173	BLT-HEX 3/8-16X4-1/2	1				
1-32	64123-50	BOLT-HEX 3/8-16X1	6				
1-33	64123-88	BOLT, 3/8-16X2-3/4 HEX	1				
1-34	64139-21	BLT-WLF 3/8-16X3/4	10				
1-35	64141-11	NUT-WLF 3/8-16 CL	2				
1-36	64141-4	NUT-WLF 3/8-16	10				
1-37	64163-12	.635/.640X1.0X.25 WASH	4				
1-38	64163-16	WASHER-41/64 X 1, 3/8 X 12	2				
1-39	64163-31	WASHER, 25/64X1X12	1				
1-40	64163-65	WASHER-.890X1.375X18	1				
1-41	64164-12	KEY-1/4X1/4X1 SQ END	1				
1-42	64164-13	1/4X1/4X2 SQ KEY	1				
1-43	64209-03	SPRING WASHER.67 ID	2				
1-44	64215-12	RIVET-POP IFI #86	7				
1-45	64221-04	E-RING.875	1				
1-46	64229-03	LOCKNUT-NYLON 3/8-16	16				
1-47	64262-012	BLT-FLG HD 3/8-16 X 1-1/4	12				
1-48	64268-03	NUT-FL NYLON LOCK 3/8-16	3				
1-49	2722543-02	BLADE-18.00 ELIMINATOR (OPTIONAL)	2				

36" EC REAR DISCHARGE DECK

EC
Midsize
Decks

FIGURE 2

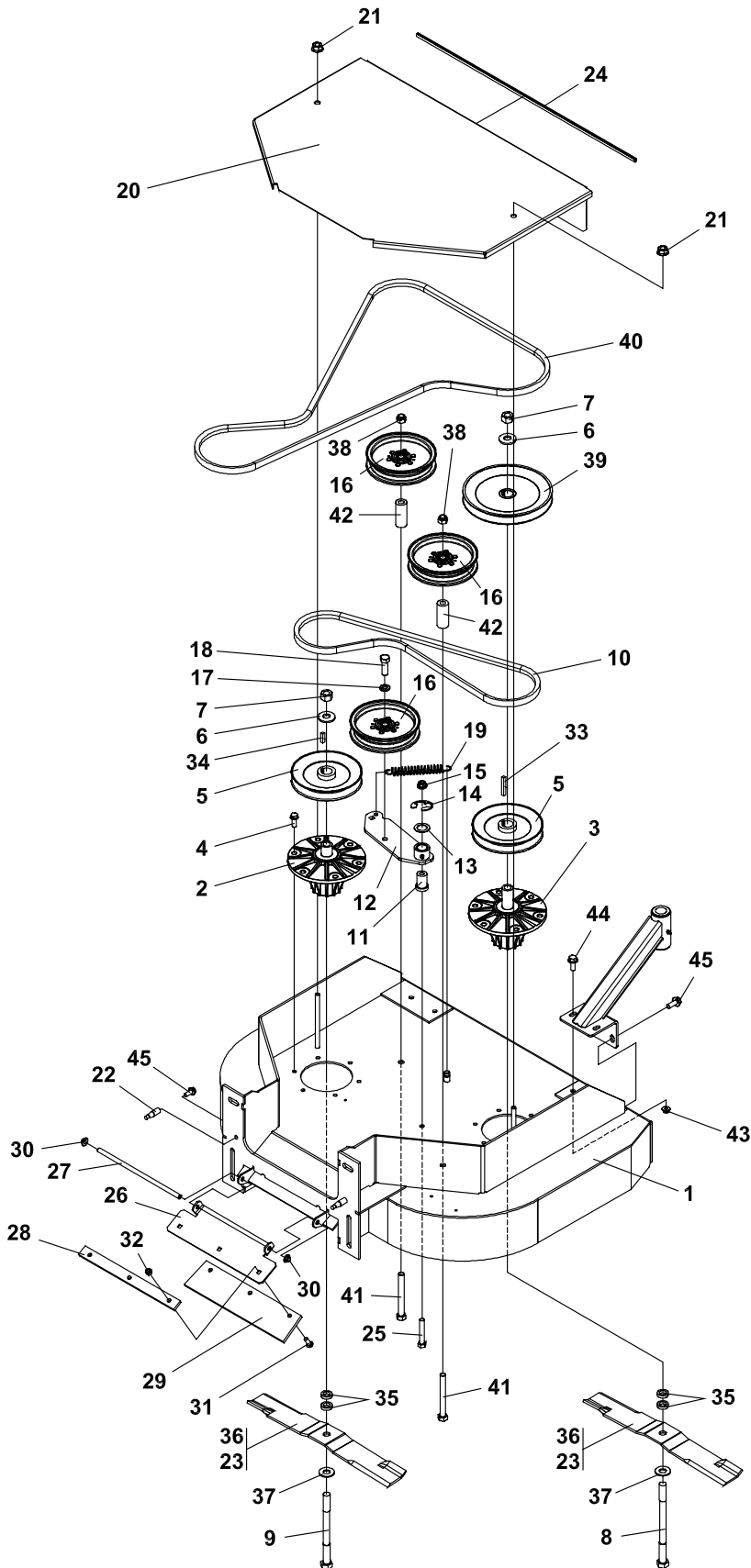

EC Midsize Decks

36" EC REAR DISCHARGE DECK

4115263-03

FIGURE 2

ITEM	PART NO.	DESCRIPTION	QTY	ITEM	PART NO.	DESCRIPTION	QTY
2-1	4115087	S-36 DECK RD W/LABS EC	1	2-38	64229-05	LOCKNUT, 1/2-13 NYLON	2
2-2	2721323	ASSY-SPINDLE SHORT (SEE FIGURE 5 FOR COMPONENTS)	1	2-39	2722161	PULLEY-6.75 EOD	1
2-3	2721097	ASSY-SPINDLE LONG (SEE FIGURE 5 FOR COMPONENTS)	1	2-40	2720815	BELT-PTO48	1
2-4	64197-003	BLT-TDFM 3/8-16 X 1.00	12	2-41	64123-74	BLT-HEX 1/2-13 X 4-1/2	2
2-5	2308140	PULLEY-ENGINE	2	2-42	4115379	SPACER	2
2-6	64209-03	SPRING WASHER 0.67 ID	2	2-43	64141-4	NUT-WLF 3/8-16	4
2-7	64025-16	NUT-HEX 5/8-18	2	2-44	64139-18	BLT-WLF 3/8-16 X 1-1/4	4
2-8	33049-02	BOLT-BLADE LONG	1	2-45	64139-21	BLT-WLF 3/8-16 X 3/4	6
2-9	33049-05	BOLT-BLADE SHORT	1				
2-10	2721477	BELT-HB 56.75	1				
2-11	4116661	PIN-PIVOT	1				
2-12	2186138.7	WLDMT-DECK IDLER	1				
2-13	64163-65	WSHR.890 X 1.375 X 18GA	1				
2-14	64221-04	E-RING.875	1				
2-15	64229-03	LOCKNUT-NYLON 3/8-16	1				
2-16	128169	PULLEY, IDLER 5.50	3				
2-17	64006-05	LOCKWSHR-HELICAL 1/2	1				
2-18	64123-05	BLT-HEX 1/2-20X1-1/2	1				
2-19	38219	SPRING-TENSION	1				
2-20	4114377.2	COVER-BELT 36RD	1				
2-21	64141-11	NUT-WLF 3/8-16 CL	2				
2-22	4119573	PIN-GUIDE	2				
2-23	2722543-02	BLADE-18.00 ELIMINATOR (OPTIONAL)	2				
2-24	108074-17	S-CHANNEL FLEX TRIM 27" (108074-17 IS A SERVICEABLE LENGTH OF 38.6")	1				
2-25	64123-88	BOLT, 3/8-16X2-3/4 HEX	1				
2-26	4114466.2	DEFLECTOR 36RD	1				
2-27	4114464	ROD-HINGE 36RD	1				
2-28	4114476.2	RETAINER-FLAP	1				
2-29	4114465	FLAP-DEFLECTOR 36RD	1				
2-30	64175-04	PUSHNUT 3/8 DIA	2				
2-31	64018-15	BLT-CRG 5/16-18 X 1	3				
2-32	64229-02	LOCKNUT-NYLON 5/16-18	3				
2-33	64164-13	1/4X1/4X2 SQ KEY	1				
2-34	64164-12	KEY-1/4X1/4X1 SQ END	1				
2-35	64163-12	.635/.640X1.0X.25 WASH	4				
2-36	112243-02	BLADE 18.00 OFFST LLFT	2				
2-37	64163-16	WASHER	2				

CASTER ASSY-FIXED DECKS

EC
Midsize
Decks

FIGURE 3

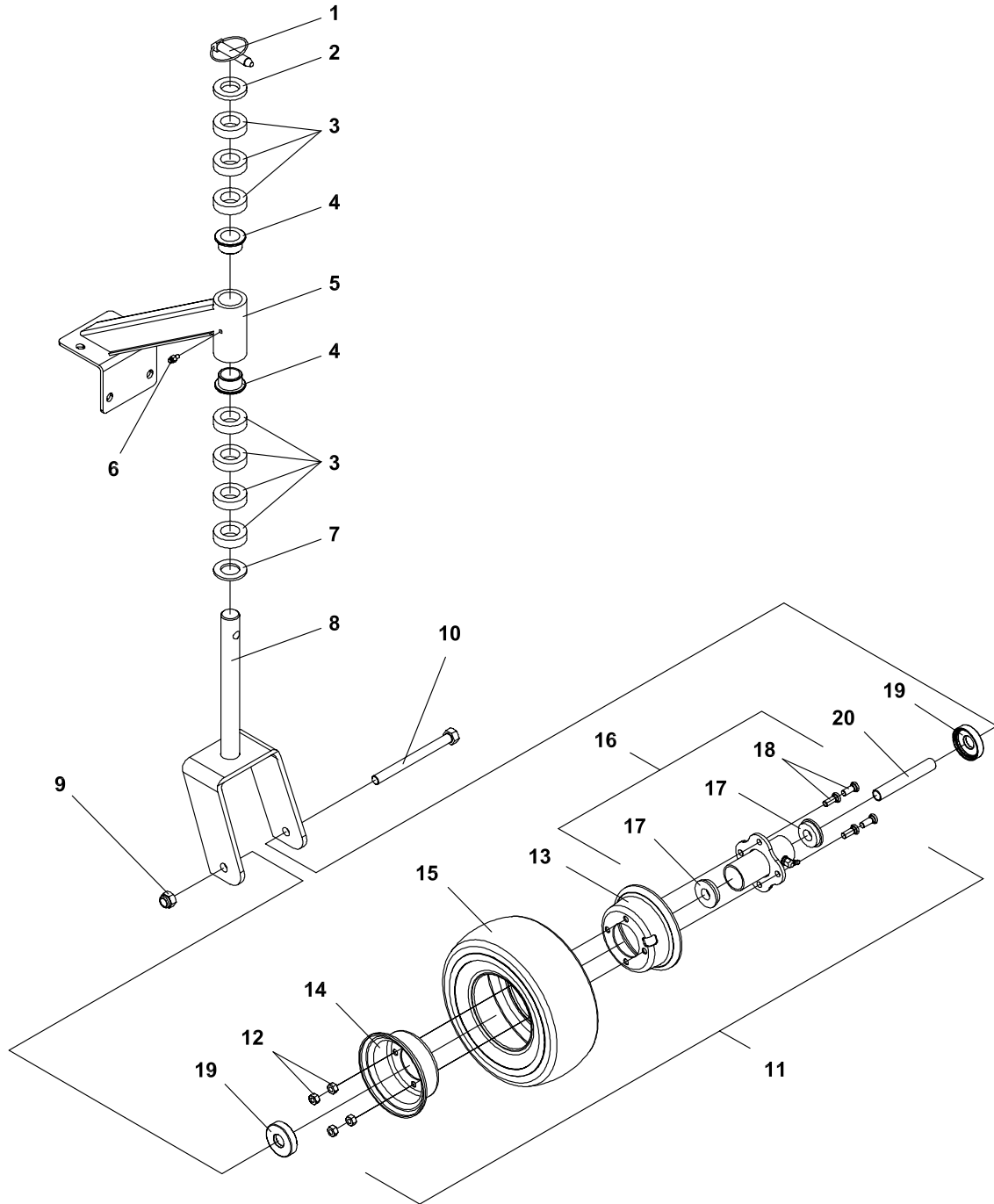

EC Midsize Decks

4115263-04

CASTER ASSY-FIXED DECKS

FIGURE 3

ITEM	PART NO.	DESCRIPTION	QTY	ITEM	PART NO.	DESCRIPTION	QTY
	4115465	ASSY-CASTER 9 IN EC (INCLUDES ITEMS 1-3, 7-11 & 20 QTYs LISTED) (NOTE 2 ASSYS REQUIRED PER MACHINE)	2				
3-1	64173-04	QUICK PIN	1				
3-2	64163-07	1-1/32X1-3/4X1/4 WASH	1				
3-3	64163-22	1-1/32X1-3/4X1/2 WASHR	7				
3-4	48053-07	BEARING, FLANGED	2				
3-5	2306029	S CASTER SUPPORT (INCLUDES ITEMS 4 & 6, QTYs LISTED)	1				
3-6	85010N	ZERK GREASE FITTING	1				
3-7	64163-84	WSHR-1.015 X 1.75 X .125	1				
3-8	2721484.7	WLDMT-CASTER YOKE	1				
3-9	64229-05	LOCKNUT-NYLON 1/2-13	1				
3-10	64123-166	BLT-HEX 1/2-13X5-1/2	1				
3-11	4114430	ASSY-WHEEL 9 X 3.5-4.00 (INCLUDES ITEMS 12 - 16, QTYs LISTED)	1				
3-12	64151-24	5/16-24 CL HEX NUT	4				
3-13	2720645	S WHL HALF, VALVE SD	1				
3-14	2720644	S WHEEL HALF	1				
3-15	4114430-01S	TIRE 9 CAREFREE	1				
3-16	2722680	HUB-9" WHEEL W/BEARINGS 1 (INCLUDES ITEMS 17-18, QTYs LISTED)	1				
3-17	2722682	BEARING-9" WHEEL	2				
3-18	64123-01	BLT-HEX 5/16-24X3/4	4				
3-19	2722591	SPACER-3/4 INCH BRG	2				
3-20	2722230-04	SPANNER	1				

SPINDLE ASSEMBLY

EC
Midsize
Decks

FIGURE 4

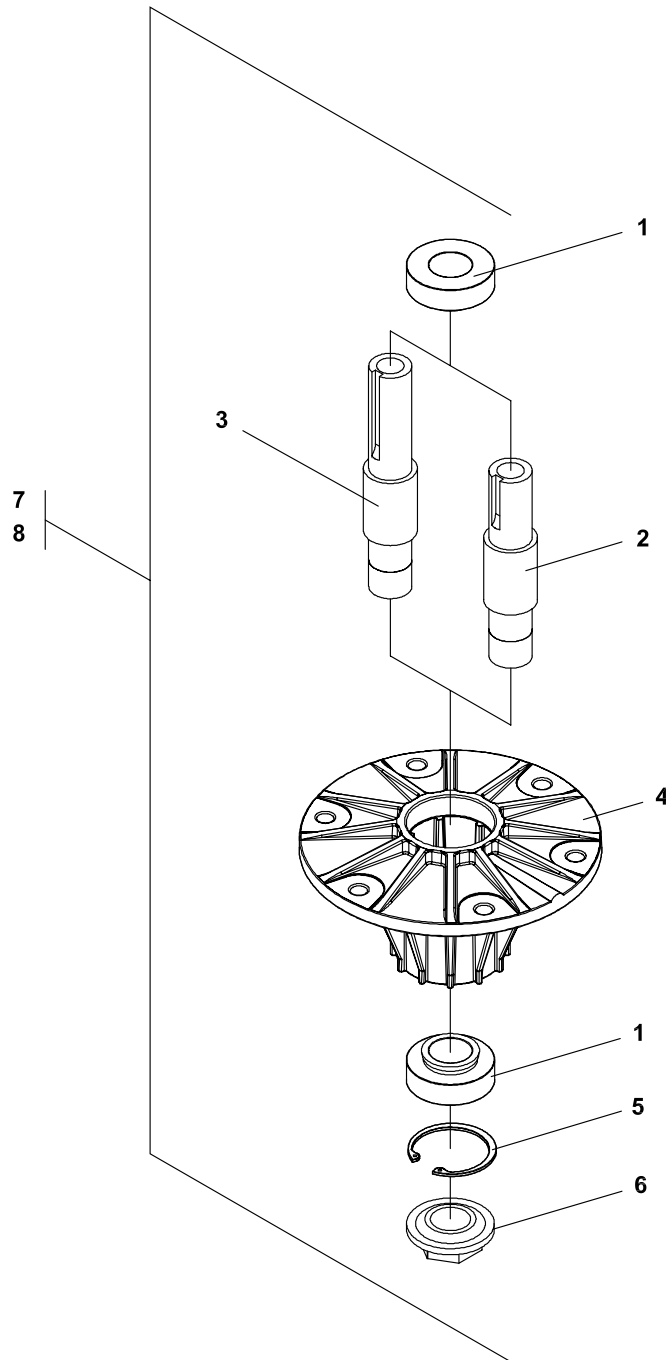

EC Midsize Decks

SPINDLE ASSEMBLY

2721694-14

FIGURE 4

ITEM	PART NO.	DESCRIPTION	QTY	ITEM	PART NO.	DESCRIPTION	QTY
4-1	38348-01	BEARING-SPINDLE SEALED	2				
4-2	33179-02	SPINDLE-SHORT (USED IN ITEM 8)	1				
4-3	33179-01	SPINDLE-LONG (USED IN ITEM 7)	1				
4-4	2721096	HOUSING-SPINDLE 6 HOLE	1				
4-5	64144-38	SNAP-RING	1				
4-6	38315	NUT-SPINDLE	1				
4-7	2721097	ASSY-SPINDLE LONG (INCLUDES ITEMS 1, 3, 4-6)	1				
4-8	2721323	ASSY-SPINDLE SHORT (INCLUDES ITEMS 1, 2, 4-6)	1				

FIGURE 5

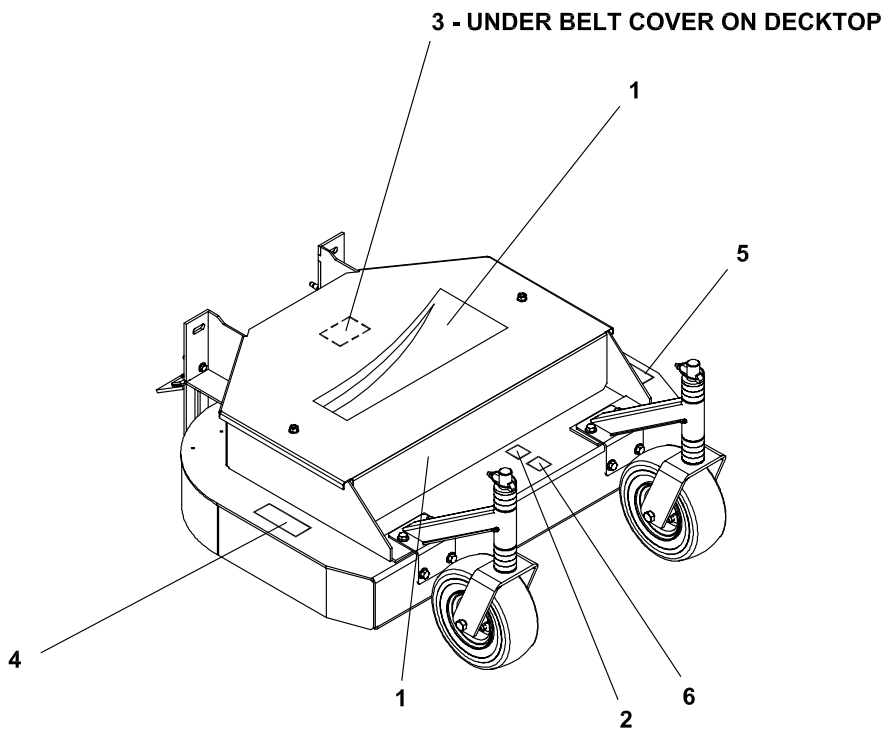
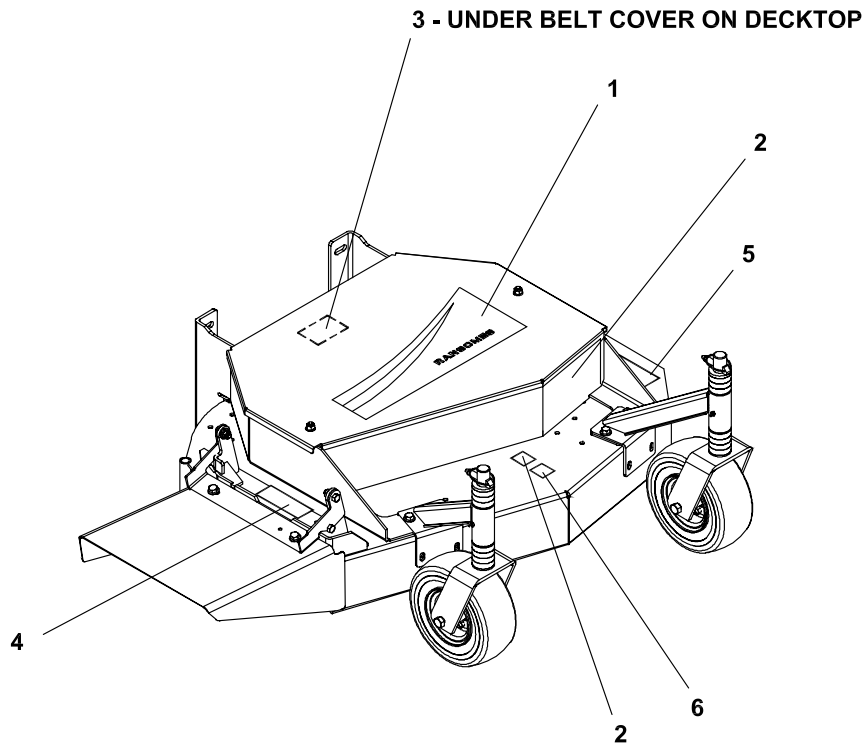

EC Midsize Decks

DECALS

4115263-06

FIGURE 5

ITEM	PART NO.	DESCRIPTION	QTY	ITEM	PART NO.	DESCRIPTION	QTY
5-1	4127946	LABEL-DK CVR-RANSOMES					
1							
	4124290	LABEL-DK CVR, BUNTON	1				
5-2	2000646	LABEL-CE 95	1				
5-3	2000638	LABEL-CON WASHER EEC	1				
5-4	2000760	LABEL-HANDS/ROCKSEC	1				
5-5	2000655	LABEL-READOPRTRSEEC	1				
5-6	009034760	LABEL-EEC NOISE 100	1				



World Class Quality, Performance and Support

Equipment from Ransomes Jacobsen Limited is built to exacting standards ensured by ISO 9001 registration at all our manufacturing locations. A worldwide dealer network and factory-trained technicians backed by Ransomes Jacobsen Parts Xpress provide reliable, high-quality product support.



BOB-CAT BUNTON CUSHMAN JACOBSEN RANSOMES RYAN E-Z-GO

Ransomes Jacobsen Limited
Central Avenue, Ransomes Europark, Ipswich, England, IP3 9QG
English Company Registration No. 1070731
www.ransomesjacobsen.com